

Mobrey ultrasonic liquid level detection systems

Features

- ▶ No moving parts
- ▶ Simple installation
- ▶ ATEX Hazardous area approval
- ▶ Ignores foams
- ▶ Unaffected by:
 - RF Interference
 - Conductivity
 - Droplets
 - Most coatings
 - Liquid colour/opacity

Description

Ultrasonic liquid level switches are for use in industrial process, nuclear and marine cargo applications to detect high or low liquid levels.

Operation is achieved using the time proven principle of ultrasonic transmission between two crystals. Liquid presence is detected by virtue of its bulk, with liquid droplets, condensation or foaming being ignored.

Mobrey Hi-sens sensors are designed for fail-safe high level duty. Mobrey gap sensors are designed for fail-safe low level duty.

Control electronics are available standard or self-checking, with options including lamps to indicate sensor status, time delays and circuits to detect wiring faults.

Mobrey has been manufacturing and selling high quality ultrasonic level equipment for many years, and have built up considerable expertise in the supply of non-catalogue equipment, custom designing system if the standard product will not meet the exact application requirements.

Typical applications

Petroleum processing

Fuels, lubricating oils, hydraulic fluids, liquid petroleum derivatives, crude oil, fuel - water interfaces.

Chemical processing

Acids, alkalis, ammonia, paints, lacquer, waxes, peroxides, alcohols, slurries, printing inks, freon.

Food processing

Beverages, fruit juices, cooking oils, molasses, liquids with entrained solids.

Pharmaceutical and cosmetic

Liquids, emulsions, lotions, solutions.

Marine operation

Fuel oil, hydraulic fluid, bilge level alarms, sea water, coolant, condensate levels, cargo levels.

Reactor operation

Level control, alarm signalling.

Cryogenic liquids

Liquid methane, nitrogen, oxygen, etc.

Water industry

Flood control, reservoir levels, sludge blanket detection, sewage sump control.

General

Leak detection, overflow alarm, low level alarm in evaporation



System description

A Mobrey ultrasonic liquid level control comprises:

- A tank mounted sensor containing transmitter and receiver crystals
- An RF sensor drive and detector electronic circuit, which may be integral with the sensor or mounted adjacent to the sensor depending upon vessel conditions or access considerations.
- A control unit mounted remotely to monitor the sensor state and provide the required switching function

Choice of sensor

Mobrey gap sensors

Mobrey gap sensors energise a relay output when there is a liquid present between the transmitter and receiver crystals of the sensor. In this way, absence of liquid, power failure or damage to plant cabling will result in an alarm condition.

Gap sensors are fail-safe low level.

Typical applications

- Pump protection
- Vessel empty protection
- Foam/froth detection
- Pump control

Mobrey Hi-sens sensors

Mobrey Hi-sens sensors operate in a reverse manner. The transmitter and receiver crystals communicate around the wall of the sensor when it is dry. Presence of liquid around the sensor damps out the 'ringing' of the sensor and an alarm condition is then signalled.

Mobrey Hi-sens is therefore failsafe high level and will signal an alarm condition on presence of liquid, power failure or damage to plant cabling.

Typical applications

- High level alarm
- Overfill prevention
- Leak detection

Ultrasonic sensor operation can be adversely affected by the presence of excessive aeration, solids or foam in the liquid. If you have an application query contact Mobrey for expert advice on the selection of a suitable liquid level detection system. Sensors may be mounted in any position to signal liquid presence.

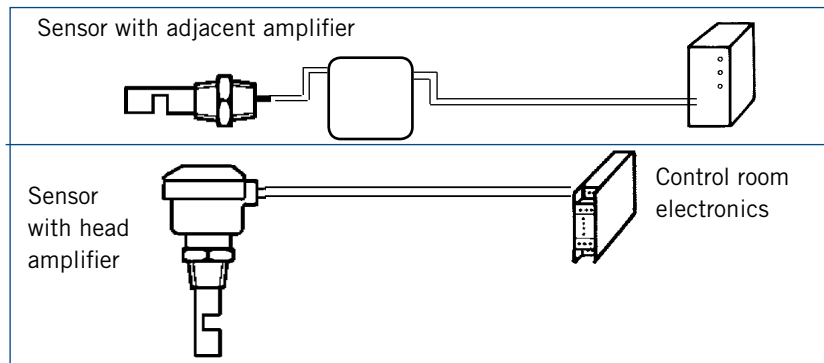

Mobrey gap sensor: General purpose failsafe low level

b) Sensor in liquid

The ultrasonic signal reaches receiver crystal

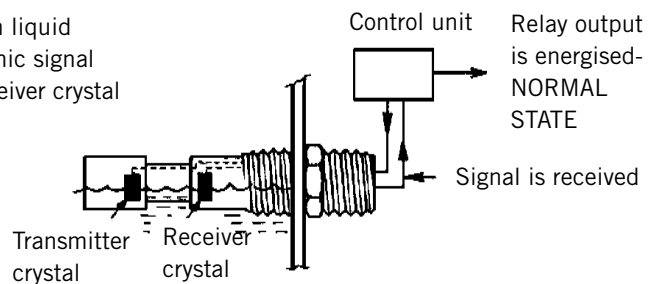

a) Sensor in air

The ultrasonic signal will not reach receiver crystal

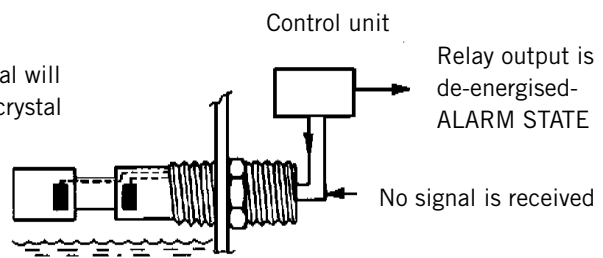

Mobrey hi-sens sensor (Models HL & HD): Fail safe high level

a) Sensor in air

The ultrasonic signal reaches receiver crystal

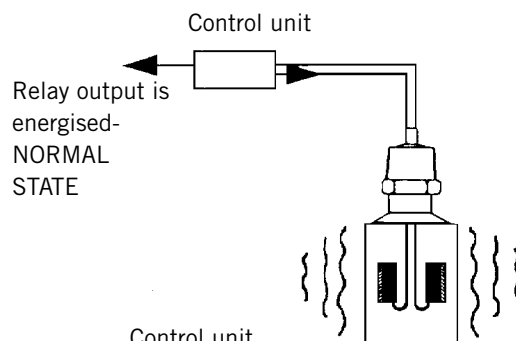

b) Sensor in liquid

The ultrasonic signal is lost into the liquid and does not reach receiver crystal

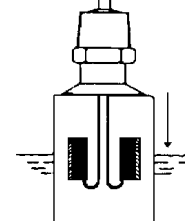

Relay output is de-energised-ALARM STATE



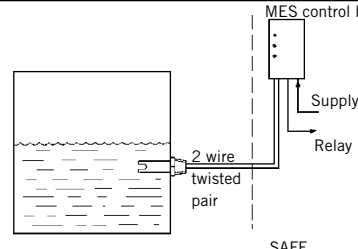

Choice of system & control unit

Select from the 3 systems below the one which meets your needs, then fold out page 16 and select a sensor to suit the liquid in the vessel.

| Standard industrial Industrial control unit |
|---|
|  <p>Safe area use only</p> <ul style="list-style-type: none"> • Wall mounting IP65 polycarbonate enclosure • Connection between sensor and control unit is by up to 50m of dual co-axial cable • Failure of sensor or breakage of co-axial cable earth loop will cause an alarm condition and light the fault LED.  <p>Description The MCU200 control unit provides simple, economical control electronics for mounting on site near the tanks containing the appropriate ultrasonic sensor. The sensors provide liquid level detection and are available in various materials and mechanical designs. The control unit has a sensitivity potentiometer to adjust for sensor and liquid type.</p> <p>MCU 200 offers in addition a selectable time delay, earth continuity checking between sensor and control unit, and LED's to indicate sensor state. MCU 200 has a DPCO relay output and is suitable for use with all Mobrey sensors.</p> <p>Select sensor: Fold out page 16 Technical data: Pages 4-7 Control electronics: Page 8</p> |

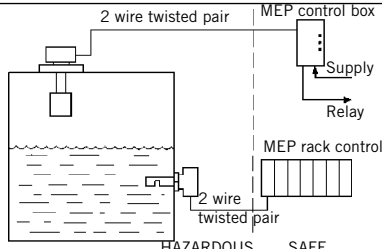
| High integrity Electrosensor |
|--|
|  <p>Intrinsically safe ATEX II 1 G EExia IIC T4 </p> <ul style="list-style-type: none"> • Cabinet or DIN rail mounting control unit • Simple twisted pair cable between sensor and control unit up to 1000m • Safe or hazardous area use • Failure of sensor or cabling will cause an alarm condition and light the fault LED <p>Additional fault relay activated on fault condition</p>  <p>Description Mobrey Electrosensor systems provide a cost effective method of level detection and control where high system integrity coupled with low cost installation is required.</p> <p>Ultrasonic sensors are fitted with head-mounted or adjacent electronics which are then connected back to control room electronics using simple twisted pair wiring</p> <p>Sensors may be set to operate either when wet or dry and have a field adjustable sensitivity potentiometer and status LED.</p> <p>All sensors are built to IS standards and may be used in safe or hazardous areas.</p> <p>Select sensor: Fold out page 16 Technical data: Pages 4-7 Control electronics: Pages 9-11</p> |

| Failsafe Electropulse |
|--|
|  <p>Intrinsically safe ATEX II 1 G EExia IIC T4 </p> <ul style="list-style-type: none"> • Cabinet, DIN rail, or rack mounting control unit • Simple twisted pair cable between sensor and control unit up to 1500m • Safe or hazardous area use • Any failure of the sensor, electronics or associated wiring causes the system to give alarm and fault outputs • Fitted with test switch to simulate alarm and fault conditions  <p>Description Designed and developed to provide the ultimate fail safe system. Electropulse electronics can be used with most Mobrey sensors. Head mounted or adjacent electronics communicate with control room electronics by sending pulses down simple twisted pair wiring. Electropulse systems are specified in applications where level is of critical importance, such as marine tanker overfilling, chemical plant and nuclear plant. Sensors may be set to operate either when wet or dry and have a field adjustable sensitivity potentiometer and status LED. All sensors are built to IS standards for use in safe or hazardous areas.</p> <p>Select sensor: Fold out page 16 Technical data: Pages 4-7 Control electronics: Pages 12-15</p> |

Ultrasonic point level sensors : Dimensions

WH shows approximate switching level with sensor horizontal

WV shows approximate switching level with sensor vertical

Extended length versions: Max A = 3000mm vertical, 915mm horizontal, where A is the measurement from the mounting thread run-out to the nominal switching point.

General purpose

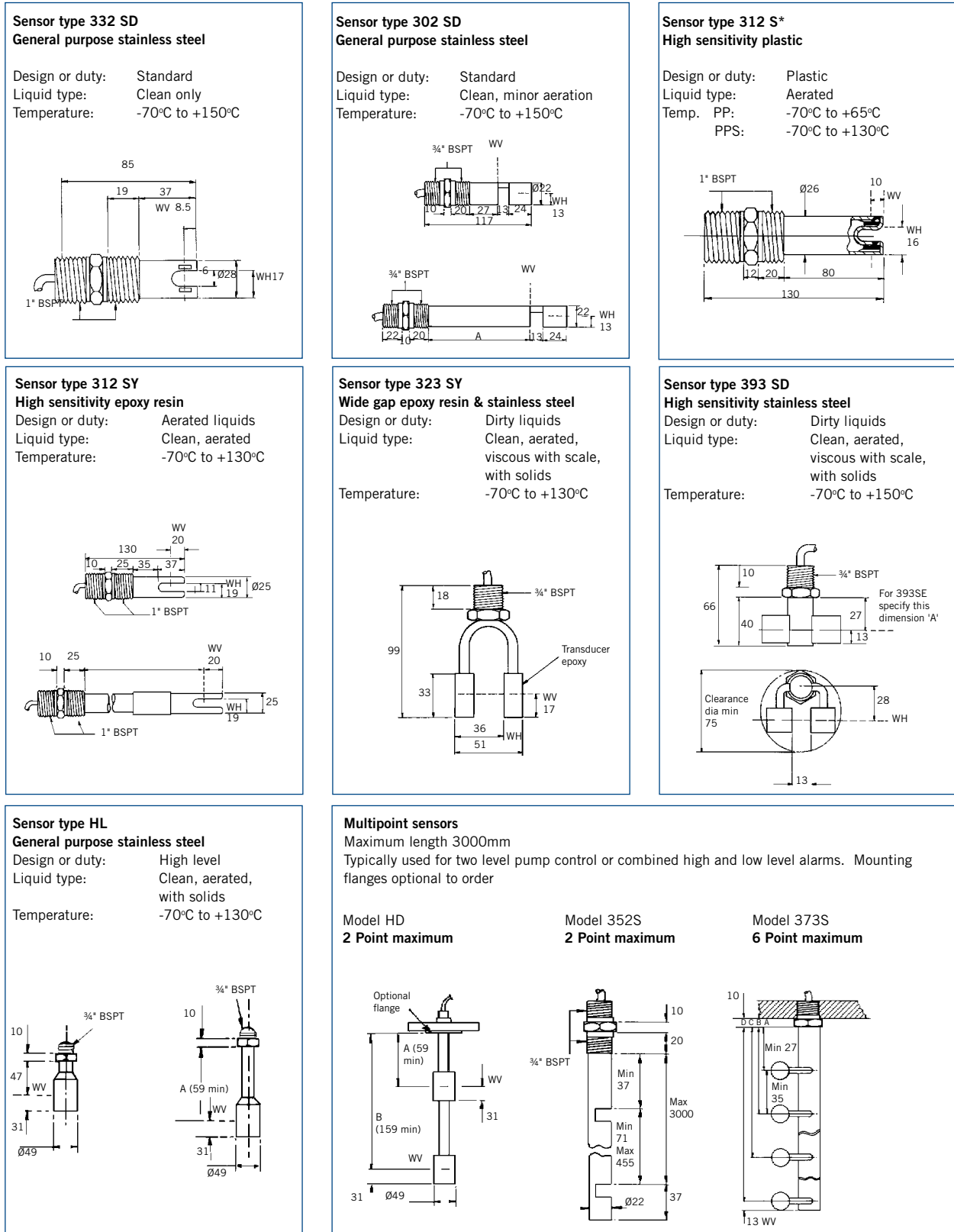

Ultrasonic point level sensors : Dimensions

Low temperature

Sensor type 362 SJ Epoxy & stainless steel

Design or duty: Cryogenic small
Liquid type: Clean, aerated,
with solids
Temperature: -210°C to +65°C

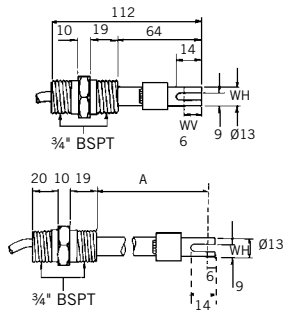

High temperature

Sensor type 30 HS High temperature stainless steel

Design or duty: High temp.
Liquid type: Clean, aerated,
with solids
Temperature: +1°C to +250°C

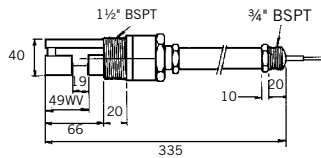

Mounts from outside vessel
Note: temperature at point of cable exit from sensor must be less than 150°C

Sensor type 39 HS High temperature stainless steel

Design or duty: High temp.
Liquid type: Aerated, viscous
with solid scale
Temperature: +1°C to +250°C

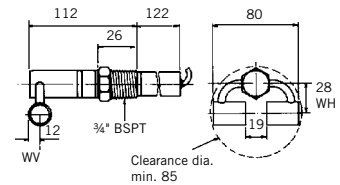

Mounts from outside vessel
Note: temperature at point of cable exit from sensor must be less than 150°C

Chemical duty

Sensor type 389 ST PTFE for chemical applications

Design or duty: PTFE body
Liquid type: Clean, aerated
Temperature: -20°C to +130°C

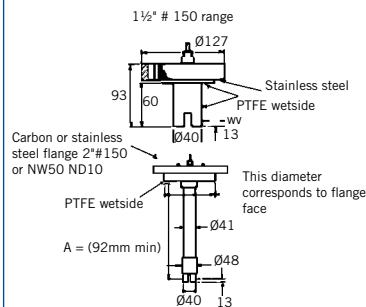

Note: Max. pressure 10 bar
(Extended length models 2.75)

Miniature sensor

Sensor type 366 SJ Miniature

Design or duty: Small space
Liquid type: Clean
Temperature: -210°C to +65°C

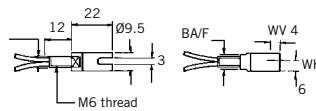

Small space model with low thermal capacity
3.5 bar max. pressure

Across pipe sensor

Sensor type 442 SD Across pipe

Design or duty: Pipelines
Liquid type: Clean or may be used
for sludge detection
Temperature: -70°C to +150°C

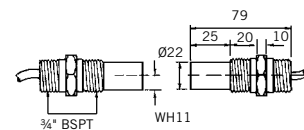

High pressure

Sensor type 422 SD Stainless steel

Design or duty: High pressure
Liquid type: Clean
Temperature: -70°C to +150°C

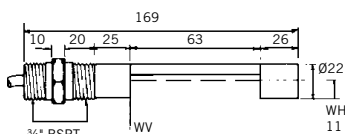

Interface

Sensor type 433 SD Stainless steel

Design or duty: Sludge or interface
Liquid type: Viscous or with solids
in suspension
Temperature: -70°C to +50°C

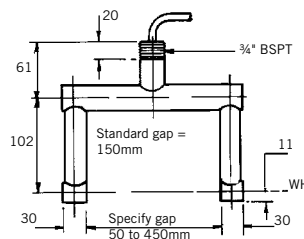

Sensor type 402 SD Stainless steel

Design or duty: Chemical interface
Liquid type: Clean, viscous with
solids
Temperature: -70°C to +150°C

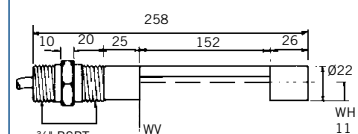

For non-penetration, interface & sludge sensors, see pages 6 & 7

Sensor technical data

| Standard sensors | 302 (352) | 30H 39H | 312 SU SR | 312 SY | 323 | 332 | 362 (366) | 389 | 393 (373) | 402 | 422 | 433 | 442 | 621 601 | HL3 (HD) |
|--------------------------|--------------|------------|-----------------|-----------|-----|-----|--------------|----------|--------------|-----|-----|-----|-----|------------|-------------|
| Repeatability (mm) | 2 | 10 | 2 | 5 | 5 | 2 | 2 | 2 | 2 | 2 | 2 | 2 | 2 | 2 | 5 |
| Max. pressure (d) (bar) | 105 | 50 | 3.5 | 21 | 21 | 70 | 3.5 | See p.16 | 56 | 105 | 280 | 105 | 105 | N/A | 100 |
| Weight (gm) | 350 | 500 | 150 | 350 | 250 | 400 | 250 | 1500 | 300 | 350 | 350 | 350 | 850 | 350 | 600 |
| Standard frequency (MHz) | 1 | 1 | 1 | 1 | 1 | 1 | 3.7 | 1 | 1 | 3.7 | 3.7 | 3.7 | 3.7 | 3.7 | 1 |

Technical data for all sensors

- Sensors are fitted with 3 meters cable and appropriate glands to fit control box.
- Power consumption is less than 10 milli-watts at sensor.
- Cable entry to sensor is IP65.
- MTBF of stainless sensors is found to be 0.15×10^6 /hr.
- Temperature shock range - 70°C to + 120°C if applicable.
- Mechanical shock - all transducers tested to withstand 20G min..
- Non operational temperature limit 175°C typical.

Sensor cable

- Standard is P.T.F.E. insulated dual coaxial with PVC sheath.
- Minimum bend radius is 35mm.
- Radiation resistant cable, suitable for 100 Mega rads, may be supplied to order.

Non-catalogue sensors

Many of our customers have particular applications for which we custom engineer and build sensors. Whatever your requirement for a level control sensor, if you can not find a suitable model in this catalogue, please do not hesitate to contact Mobrey for further discussion.

Non-penetration liquid level sensors

Type 621

- No contact with liquid
- No penetration of vessel
- For 18 to 75mm OD pipes

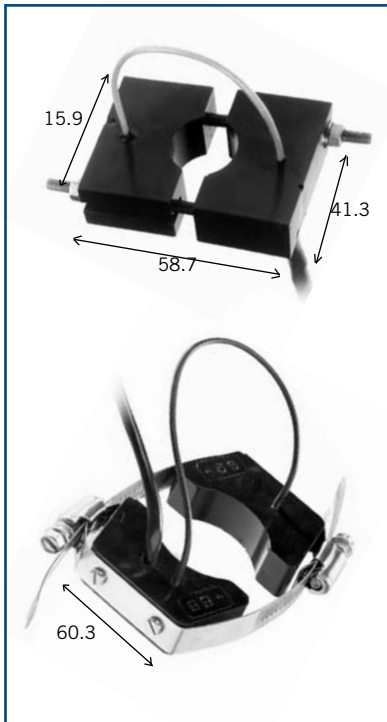

Description

The 621S ultrasonic liquid level sensor is mounted outside the sight glass or pipe to be monitored, at the required switch position. The two parts of the sensor are accurately aligned on site on either side of the pipe. Using epoxy resin or silicone grease, the ultrasonic signal is coupled into and through the pipe wall into the liquid or gas within the pipe. Liquid allows transmission to the opposite wall and through to the other part of the sensor. The sensors are connected to a adjacent head amplifier unit, to provide a liquid presence relay output.

Technical data

- Repeatability: Typically 2mm depends on application
- Housing: Epoxy resin
- Temperature: -20°C to +130°C
- Cable: 3m PTFE coaxial cable
- Adhesive bond: Epoxy resin pack supplied with every sensor pair
- Mounting: Horizontal preferred

Model numbers

Pipe size: Models are available to suit most pipe outside diameters within the range 18mm to 75mm. Accurate sizing is important to ensure reliable operation state with order the tube or pipe outside diameter for each application.

Typical installation

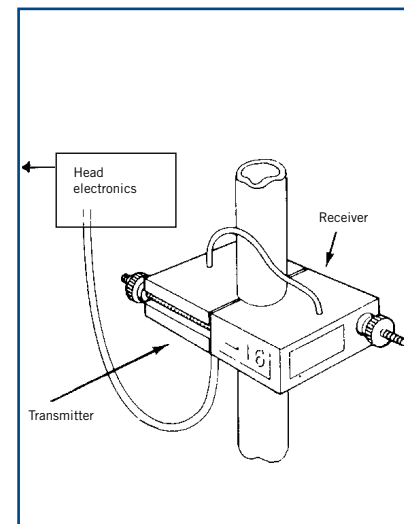

Interface detection and sludge measurement

Ultrasonic technology can be used to discriminate between immiscible liquids, to indicate the interface and to detect and monitor suspended solids.

Interface detection

For interface detection between immiscible liquids, two techniques are available: ultrasonic attenuation and ultrasonic reflection.

Both techniques use standard Mobrey liquid level control electronic systems. Suitable sensors for interface monitoring, are typically the larger gap types, that is 150mm upwards.

Interface detection by attenuation

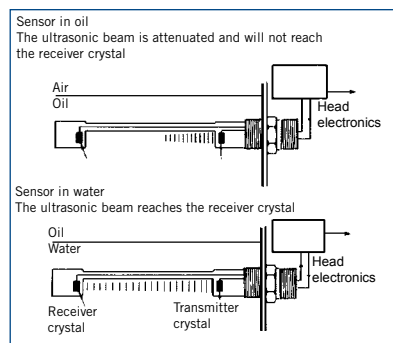

Ultrasonic attenuation is the reduction in energy of the beam as it is transmitted through the liquid. Viscous liquids, emulsions and liquids with entrained solids generally have a higher ultrasonic attenuation than low viscosity clear liquids such as water. When the attenuation difference is sufficient, the amplifier gain can be adjusted so that the ultrasound beam passes through the less attenuative liquid but is stopped by the more attenuative liquid. The output relay can then be set to monitor which

Multipoint & special combination sensors

Special sensors

Special combinations of sensors are produced for specific applications - e.g. combined sludge blanket detectors, pump controls and very high level alarms. Such combinations are designed and engineered for each individual application, whether for shipboard high level alarms, waste processing plants or reservoir control systems. Contact the sales office for further information.

Multipoint sensors

Ultrasonic sensors are easily combined into multi-point transducers for two level pump control or combined high and low level alarms.

liquid is in the gap.

The ultrasonic attenuation of a liquid depends on many factors, the main ones being the complexity of the molecule, followed by the viscosity, assuming there is no aeration. Many liquids can be distinguished by this technique and for further information on previously tested liquid systems consult our technical sales. If samples of the liquids are available then a simple site test can often be done.

Interface detection by reflection

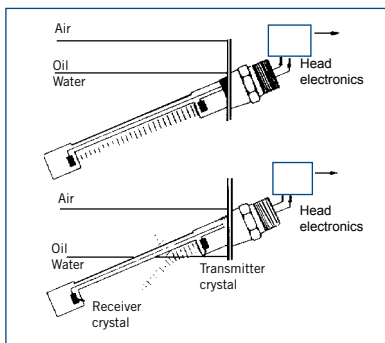

When two immiscible liquids have similar attenuations the above method cannot be used, however it is likely that the velocity of ultrasound will be different. In this case a beam of ultrasound passing through the interface will be reflected and refracted and if the sensor is arranged at a shallow angle the effect is that the transmitted beam tends to miss the receiver and is thus effectively attenuated. An angle of 10 degrees is chosen and often this results in total internal reflection of the transmitted beam. Thus when the interface is within the gap of the angled sensor,

very little ultrasound reaches the receiver, but when the interface is above or below the sensor (ie in either liquid) then there is a large signal present. The control unit gain is set to actuate the relay when the interface is in the gap. Note this condition will also occur if the upper liquid drains away and air (gas) is in the gap. Note for further information on suitability of this application consult our technical sales.

Suspended solids measurement

Solids suspended in a liquid will scatter ultrasonic beams, causing attenuation. This attenuation depends on the size and nature of the particles and for typical sewage sludges it is possible to use Mobrey ultrasonic systems to detect 1% to 15% w/w. Industrial slurries such as fine pottery slips can often be measured to 65%, but coarse granular material is often very attenuative. Leaflet IP250 gives details of Mobrey sludge measurement systems.

Interface and sludge monitoring

Typically sensors with gaps of 150mm or larger are used for interface and sludge measurement. These sensors are standard types 402, 433 and the 442 (a pair of sensors for mounting across or along a pipe section). Special flanged sensors with the 10 degree tilt built in are also available. Generally these sensors work at 3.7MHz and are compatible with Electropulse and Electrosensor electronics or plant mounted MCU200 electronics.

Typical standard sensors are:

Model HD - A two point dual high level sensor using two Hi-sens HL sensors. This is typically used for 95% and 98% high level alarm on marine cargo tankers, for outline dimensions see page 9.

Model 373 - A multipoint version of the 393 sensors, with up to 6 switching levels.

Fitting: 3/4" BSPT from inside the vessel. Option: flanged to customer specification

Model 352 - Two point version of the 302 type sensor, fitted from inside or outside of vessel

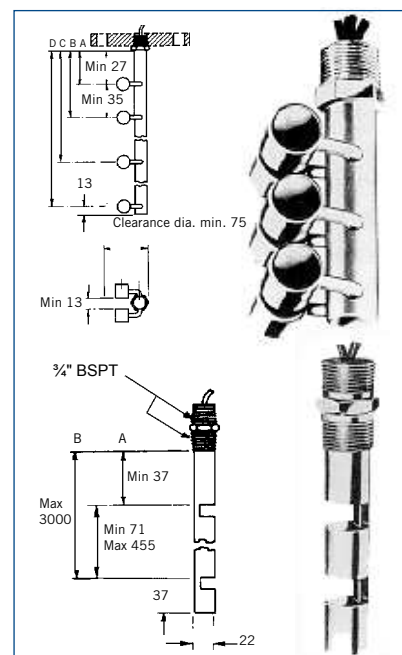

Mobrey standard industrial control unit MCU200

- Simple economical control unit
 - IP65 enclosure
 - 115v/230v AC or 24v DC
- Features:
 - Sensor status LED
 - Time delay
 - Cable check
 - Pump control

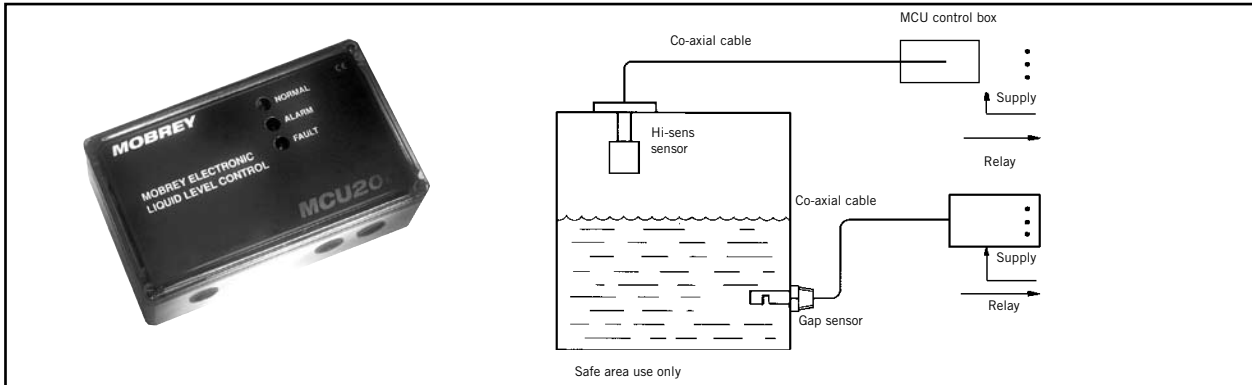

Description

The MCU200 control unit provides simple, economical control electronics for mounting on site near the tanks containing the appropriate ultrasonic sensor. The sensors provide liquid level detection, and are available in various materials and mechanical designs. (See fold out page 16).

The control unit provides a relay output for external control or alarm functions according to whether the sensor is wet or dry. The MCU 200 has a dual pole relay output energised when the sensor is wet, LED indicators, time delays and cable check facilities preselectable. The MCU200 will operate with all Mobrey ultrasonic sensors and can accept a voltage free contact input from another level switch to give a pump control function on the output relay.

Installation

Mobrey ultrasonic sensors are normally fitted with 3 metres of dual coaxial cable. This cable can be extended with suitable coaxial extensions up to 50 metres. Suitable cable is part No. K178, or two lengths of coax type RG178 can be used.

The coaxial cables are terminated in the control unit. The output cabling from the control unit comes from the relay output terminals as a wet/dry changeover switch. This can be used to trigger an alarm or provide an input into a control system.

Technical data

MCU200 Features

Suitable for all Mobrey ultrasonic point sensors
Frequency selection by switch on PC board.

Relay

Energised for sensor wet or dry selectable by switch.

LED indicators

Visible through the box lid. Green for normal. Red for alarm. Selectable for wet/dry sensor as appropriate for the application.

Amber LED for fault condition.

Gain potentiometer

Fitted with scale and separate range switch to adjust for sensor type and site conditions.

Response time

Selectable delay of 0.5, 2, 8 or 30 seconds. Delay selectable wet to dry or dry to wet. 50 ms response in opposite direction.

Sensor cable check

Selectable to monitor coax screen to sensor for continuity.

Fault lights fault LED and sets relay to alarm state.

Auxiliary input

External closed circuit input to MCU 200 latches the output relay to achieve pump control.

| | MCU201 | MCU203 |
|---------------------------------------|----------------------------|--------|
| Power supply (Selector switch) | 110/120V ac 220/240V ac | 24V ac |
| Power consumption | TBA | |
| Relay output | DPCO | |
| Relay rating | 5A at 230V | |
| Box dimensions | 200 x 120 x 75 | |
| Box rating | IP65 Polycarbonate | |
| Holes for glands | 3 off 16mm dia, | |
| Fixing centres (WxH) | 188 x 88 | |
| Fixing hole diameter | 4mm | |

The MCU200 product range generally replaces control units types T396 & T496

Description

An Electrosensor system comprises an ultrasonic sensor with associated 'head' electronics, are either mounted directly on the sensor or in an adjacent wall mounting

box, and control room electronics. Connection between sensor electronics and control electronics is by standard twisted pair instrument cable, typically over distances of up to 1000m.

Control room electronics

- Provides intrinsically safe power supply to sensor electronics and detects sensor state.
- Operates output relays and front panel LEDs
- Monitors plant wiring integrity

Principle of operation

The twisted pair supplies a DC voltage from the control electronics to the sensor. The current drawn by the sensor is used to signal the sensor state. This current signalling is detected by a trip amplifier in the control electronics. The control electronics include a fault monitoring circuit to detect if the current drawn is outside preset limits, such as would occur on cable breakage or short circuit. Electrosensor can be used in all areas of the plant. Some users may prefer to provide their own supply and alarm circuits. Electrosensors are fully system certified to accommodate this need, enabling connection to PLC or other control circuits via standard Zener safety barriers when the sensor is in a hazardous area.

MES3L/*S
control room unit



Ordering information
MES3L/1S: 230V ac
MES3L/2S: 115V ac

MES2D/3S
control room unit
(External barrier required)



Ordering information
MES2D/3S: 24V dc

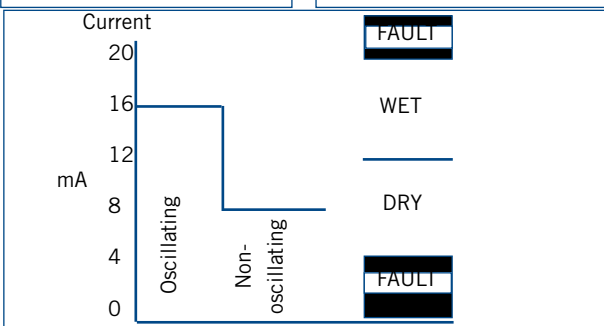

The graph plots Current (mA) on the y-axis (0 to 20) against sensor state on the x-axis. It shows an 'Oscillating' state at approximately 16 mA and a 'Non-oscillating' state at approximately 8 mA. 'FAULT' indicators are shown at the top and bottom of the graph, 'WET' is shown above the 8 mA line, and 'DRY' is shown below the 8 mA line.

Specification

| Common specifications | |
|-----------------------------------|--|
| Design concept | Will de-energise relay on loop current levels falling outside of preset limits (i.e. open or short circuit). All control room electronics have visible LEDs to indicate sensor and fault detection circuit status. |
| LED indicators (3) | Alarm relay on, Alarm relay off, fault detected |
| Approval | ATEX II(1)G [EExia] IIC (MES2D/3S requires separate external safety barriers ATEX II (1) G for connection to the sensor in a hazardous area.) |
| Stand alone electronics: MES3L/*S | |
| Alarm relay output | Operates one electrosensor or two sensors for pump control Selectable: energised for sensor wet or sensor dry using PCB switch. When two sensors are connected, relay assumes a pump control function and PCB switch now selects whether the relay is energised to fill or empty the tank between the two sensors. |
| Fault relay output | De-energises on fault condition. PCB switch to select whether the fault condition also de-energises the alarm output relay. |
| Relays (2) | SPCO 100V A max/ 5 A max. |
| Cable entry | Via base cutouts through rubber grommets to terminal strip. |
| Voltage | MES*L/1S: 230V ac 50/60Hz MES*L/2S: 115V ac 50/60Hz |
| Output to sensor | Mains powered units: 12v DC intrinsically safe, fully floating (galvanically isolated) |
| Delay | 0.5s wet to dry 50ms dry to wet |
| Ambient temp | 60°C |
| Power consumption | 8VA |
| Protection | IP20 |
| Power supply tol. | AC mains +/- 10% |
| DIN rail electronics: MES2D/3S | |
| Alarm relay output | Operates one electrosensor and is suitable for cabinet mounting on standard DIN rail. Includes fault monitoring to detect abnormal current level and operate alarm relay. |
| Rating: | SPCO 100VA max/ 5 A max |
| Time delay | Adjustable 0.5 to 20s either wet to dry or dry to wet. |
| Connections | Terminal strip. |
| Voltage | 24V dc: 10-30V |
| Output to sensor | 24v dc powered units: 24V dc fully floating (galvanically isolated). External zener barriers required when sensor in hazardous area (refer to system certificate) |

Electrosensor head electronics

Most of the sensors on pages 4-5 can be specified with Electrosensor electronics. 1 MHz sensors with dual screwed fittings can be specified with head mounted electronics housed in a tough nylon enclosure integral with the sensor. A field adjustable gain potentiometer and an LED indicator, visible through the end cover to show sensor status are provided. A selector switch to set the 16mA signal to occur either with the sensor wet or dry is also provided. A terminal with PNP output allows direct connection to a PLC input via a third signal wire. Sensor head electronics are also available in an adjacent wall mounting enclosure, for use with any 1MHz or 3.7MHz sensor. These electronics are used where it is not possible or desirable to mount the electronics directly on the sensor. Connections between adjacent electronics and sensor is by dual coaxial cable (maximum length 10m).

Head electronics



The Electrosensor model no. as selected from page 16 includes head electronics, code **SSH**.

Adjacent electronics: MES3AI



Suitable sensor must be selected from page 16 code **U8H** only

Head mounted (integral) electronics

Mounted in a tough glass filled nylon enclosure weatherproof to IP66/IP67 the head electronics drive the sensor and detect its state; either wet or dry. Connection is via the M16 cable gland (supplied). Removal of the housing cover reveals:

- Adjustable gain potentiometer to set the sensor to suit application conditions.
- Mode selector switch.
- Connections for control electronics.
- LED to indicate sensor state (visible through window in end cover)

Adjacent mounted electronics

The sensor drive and detector electronics are enclosed in a wall mounted IP65 polycarbonate box which is wired to the sensor using dual co-axial cable (maximum length 10m). Connection is via 2 M16 cable glands (supplied). Removal of the box lid reveals:

- Sensor frequency selector switch (1Mhz or 3.7Mhz)
- Coarse and fine grain adjustment to set the sensor to suit application conditions.
- Mode selector switch.
- Connections for sensor and control electronics.
- Output selector switch for 8-16mA current loop operation. If PLC operation is selected, current drawn is set to approximately 8mA in both sensor states (wet or dry).
- LED to indicate sensor state (visible only when box lid removed).

Specification

| | |
|-----------------------------------|--|
| Hazardous area or approval | Electrosensors are approved intrinsically safe ATEX II 1 G EExia IIC T4 (-40°C ≤ Ta ≤ +85°C) T5 (-40°C ≤ Ta ≤ +40°C) and can be used with control room electronics (Page 9) or used in an intrinsically safe system. |
| Power input: | 12 -24V DC from associated MES control room electronics or other suitably protected source. |
| Sensing: | Draws either 8 or 16mA on a current loop dependent upon sensor state and mode switch setting. |
| Mode selector | Gives choice of current level for sensor state. Would typically be set for 16mA with sensor switch oscillating (i.e gap sensor wet, Hi-sens dry) |
| Output selection | Both types of head amplifier have a transistor output on a third terminal, suitable for signalling to a PLC or similar device. This transistor output switches upto 30mA at the supply line voltage onto the third wire. |
| Ambient temp. | - 40°C to + 60°C |
| Earthing | Head electronics are floating with respect to sensor body. Sensor body may be earthed through tank connection. |
| Plant cabling | Standard twisted pair instrument cable recommended with screen (screen not connected at head electronics). Maximum loop resistance 30 ohms. Cable parameters must conform to ATEX requirements. |
| Users own electronics | Electrosensors on this page can be used in any intrinsically safe system. The user must ensure that suitable safety barriers are used. |

Electrosensor ordering information

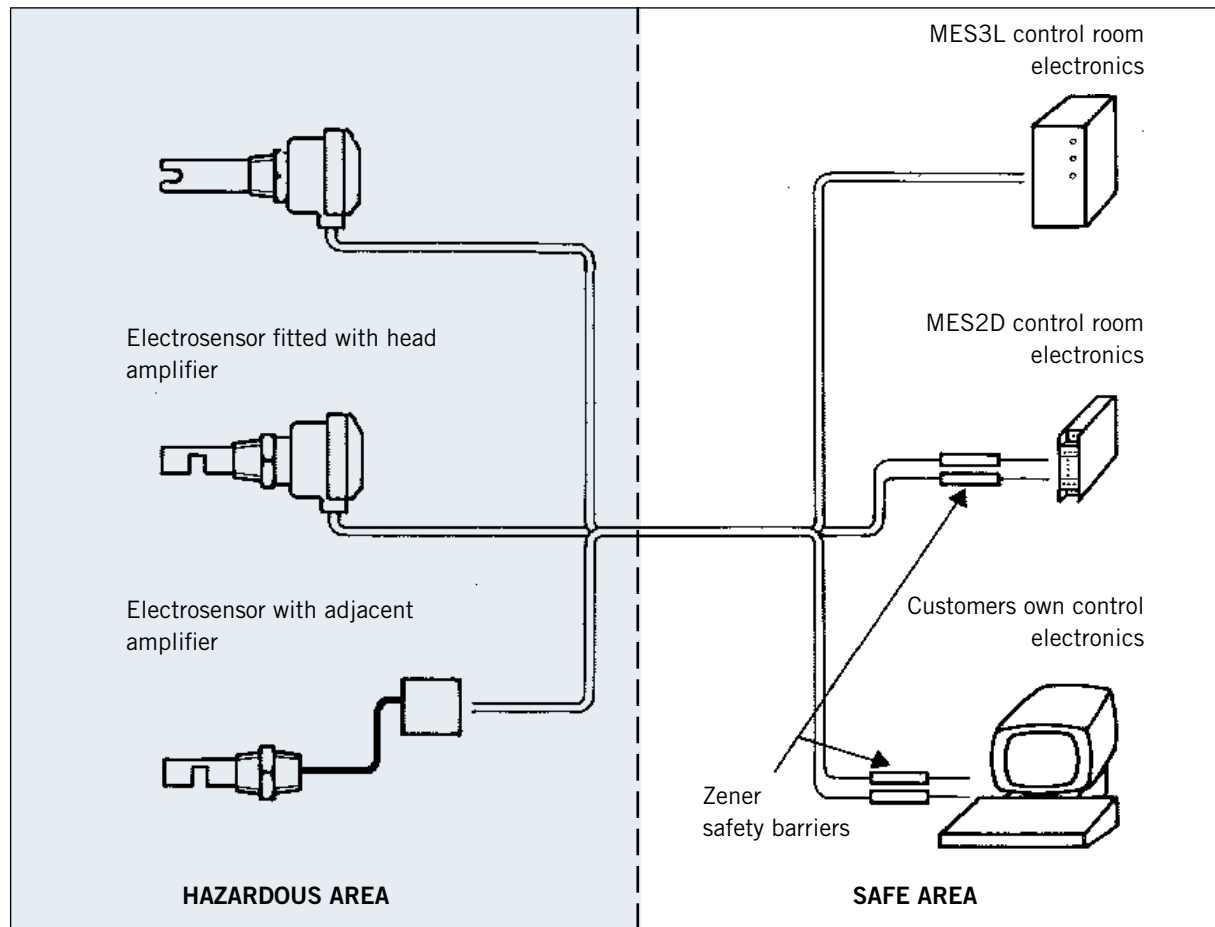

Ordering information - control room electronics

| MES | Mobrey Electrosensor | | | |
|-----|----------------------|---|---|----------------------|
| | Code | Approvals | | |
| | 3 | Intrinsically safe (type L enclosure only) | | |
| | 2 | Non I S | | |
| | Code | Enclosure | | |
| | D | DIN rail enclosure (requires external safety barriers for IS use) | | |
| | L | Stand alone enclosure | | |
| | Code | Voltage input | | |
| | 1 | 230V ac MES3L only | | |
| | 2 | 115V ac MES3L only | | |
| | 3 | 24V dc (non I S) | | |
| | Code | Relay output | | |
| | S | SPCO | | |
| MES | 3 | L / 1 | S | Typical model number |

Ordering information - control room electronics

| | | |
|------------------------------|----------------------------|-----------------------|
| Sensor Head amplifier | Fold out page 16 MES3AI | Select type ***SDU8H* |
|------------------------------|----------------------------|-----------------------|

Ordering information - control room electronics

| | | |
|-------------------------|------------------|-----------------------|
| Sensor/amplifier | Fold out page 16 | Select type ***SDSSH* |
|-------------------------|------------------|-----------------------|

Section 5 - Electropulse systems

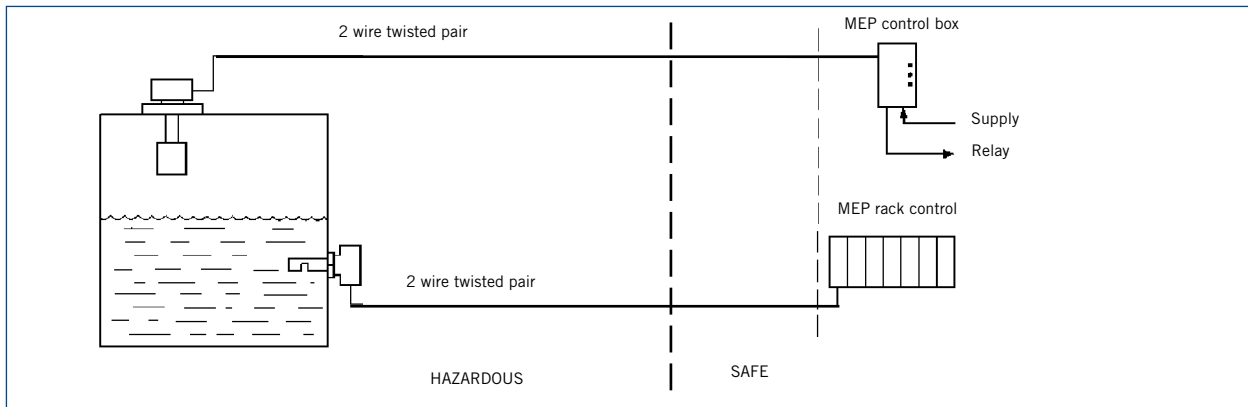

Electropulse systems provide the ultimate in fail safe liquid level alarm. Standard sensors are fitted with a head amplifier which communicates with a control room unit using standard twisted pair instrument wire. Using a gap sensor for low level and a Hi-Sens for high level, a system is constructed such that any failure: mechanical, electronic or in the communication line, causes the system to fail safe.

Electropulse control room mounted electronics provide front panel LED indication of the level sensor status, plus a change-over relay output, rated at over 500VA, to control pumps, alarms or signal to the controller. The green LED labelled "NORMAL" indicates that the sensor is in its oscillating condition. For all gap sensors the oscillating condition is the wet condition, for Hi-Sens sensors this is dry (see over). The red LED indicates that the sensor is not oscillating, which is defined as "Alarm".

A further LED, yellow, indicates a "Fault" condition, resulting from plant cabling faults or head amplifier damage to either of these causes the current in the control loop to deviate from normal value. The fault condition automatically triggers the alarm relay and the red alarm LED. The Electropulse MEP3R units are cards suitable for mounting in the standard 19" MEP3B rack, up to 14 units per rack. These MEP3R cards are available with either SPCO or DPCO alarm relay and a separate SPCO fault relay. The Electropulse MEP3L units are single units housed in a plastic case, suitable for wall, panel or DIN rail mounting..

These units are only available with one combined DPCO alarm/fault relay.

For hazardous area operation the MEP3R and MEP3L units have intrinsically safe sensor output connections. When used with the appropriate sensor, the system is approved intrinsically safe to ATEX standards.

Plant cabling

The Electropulse control room readout units are connected by a twisted pair instrument cable, preferably screened, to the Electropulse head amplifier. This twisted pair provides approximately 12 Volt DC at 15mA to power the head amplifier and sensor: current pulses of 2mA at approximately 240Hz signal that the sensor is in the oscillating or NORMAL state. The ALARM state is indicated by constant current drain. Loop resistant of the two wire cable must be less than 35 ohms. The audio current signalling provides a noise and RF interference resistant transmission over long distances.

Head amplifier

Electropulse head amplifiers provide the necessary interface between the ultrasonic liquid level sensor and the control room electronics.

The head amplifier is either mounted directly onto the sensor or is mounted on the plant close to the sensor. The head amplifier is a tuned RF amplifier at either 1 MHz or 3.7 MHz to suit the sensor. When the attenuation between transmitter and receiver piezoelectric crystals is low enough, the amplifier oscillates. This is the NORMAL or oscillating condition of the sensor. The oscillation frequency is divided down by normal digital circuitry until a square wave at around 240 Hz is obtained. This is used to switch the 2mA current drain on and off across the supply line from the control unit. Head amplifiers are available in IP66/IP67 aluminium housings and IP68 gunmetal housings when mounted on the sensor and in an IP65 polycarbonate box for plant mounting adjacent to the sensor. Optionally available, a push to test switch on the head amplifier allows an operator to simulate alarm conditions, for shutdown testing. Other options include two separate head amplifiers in one IP68 housing, and stainless steel housing material.

"Normal" sensor state

For gap sensors, the NORMAL condition occurs when the sensor is immersed in liquid. Hi-Sens sensors oscillate and give NORMAL indications when the sensor is in air, dry. The NORMAL condition with an active oscillating sensor is the best state for a level alarm system, since all components are energised and active. Such a system is 'fail safe'.

System selection

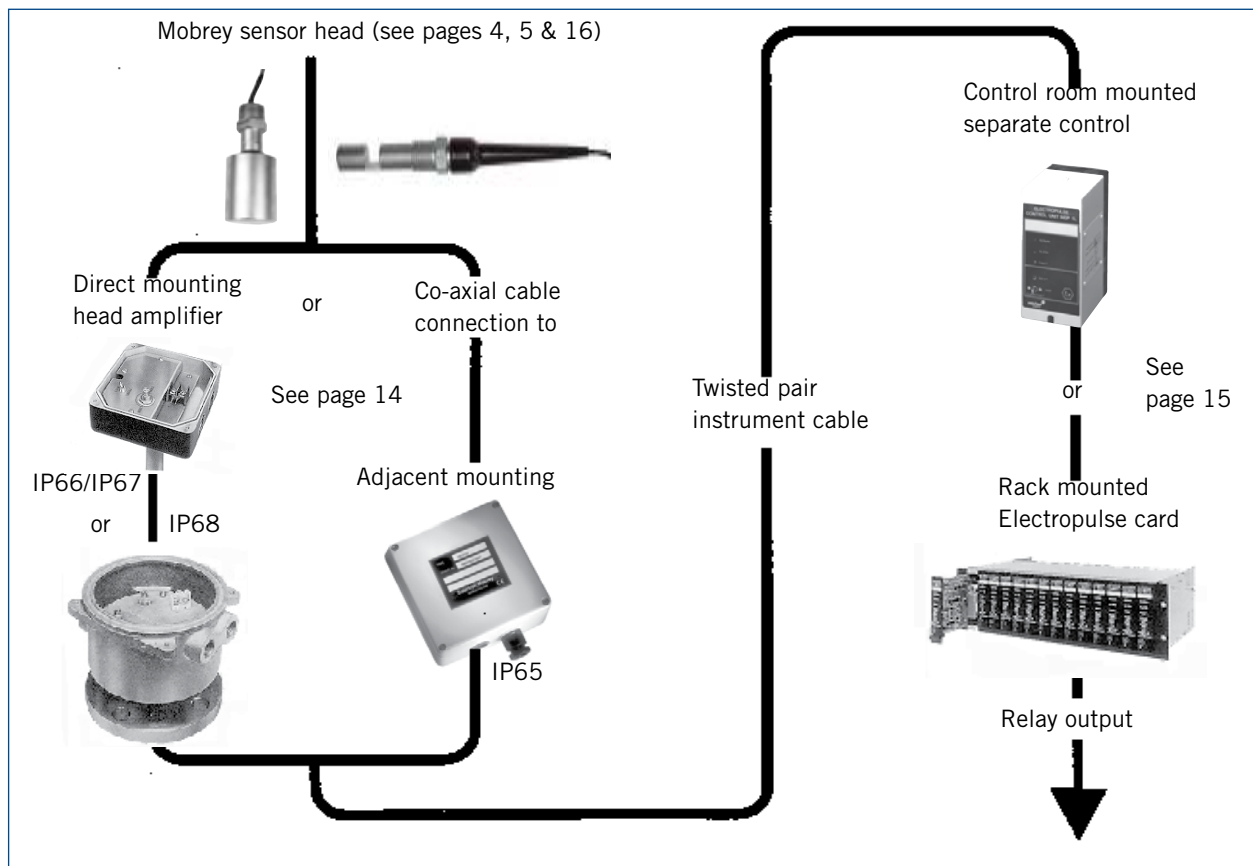

An Electrosensor system comprises three modules:-

| | |
|----------------------------------|--|
| Liquid sensor: | Fold out page 16 and select the most appropriate sensor for your application. (For adjacent mount electronics see Page 17) |
| Control room electronics: | Descriptions are given on page 15 - choose wall/DIN rail mounting or rack mounting. Ordering information is given on page 17 |

Typical system (Direct mounting head amplifier):

| | |
|----------------------------------|----------|
| Liquid sensor: | 302SDPIH |
| Control room electronics: | MEP3R/1S |

Typical system (Adjacent mounting amplifier):

| | |
|----------------------------------|-------------|
| Liquid sensor: | 312 SU U8H |
| Adjacent amplifier: | MEP3AI/3CPN |
| Control room electronics: | MEP3R/1S |



Industrial sensor head amplifier

1. Industrial sensor head mounted amplifier unit

The head amplifier is mounted on the sensor in an IP65 (IP66/IP67 when suitably glanded) aluminium die cast box. Cable connection via one or two PG16 gland holes. Sensor gain potentiometer adjustable and gain switch accessible with lid removed.



Marine sensor head amplifier (IP68)

2. Marine sensor head mounted amplifier unit

The head amplifier housing in either gunmetal or stainless steel is permanently mounted on the sensor flange. Cable connection is via one of the M20 gland holes, into cable clamp and corrosion resistant terminals. Amplifier board is coated with polyurethane varnish and is optionally resin potted. Lid is 'O' - ring sealed. Gain control adjustment potentiometer is factory preset, but site adjustable. For use with two point sensor two totally separated head amplifiers can be housed in one MARINE housing. The general design concept of the marine sensor head amplifier is based on the worst case of deck mounting on a chemical tanker. Typical application involves two Hi-Sens sensors positioned for 95% and 98% high level alarms.

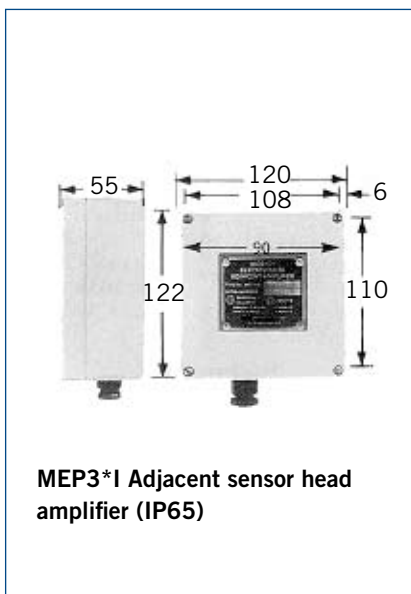

MEP3*1 Adjacent sensor head amplifier (IP65)

3. Adjacent sensor head amplifier

Housing polycarbonate box designed for mounting adjacent to the sensor. Sensor coaxial cables are attached to terminals in the housing, and the twisted pair plant cable fits through an M16 plastic gland. Gain switch and adjustment potentiometer are accessible with the lid removed.

Reverse action unit

With standard head amplifiers as above, the "NORMAL" condition on control room readout unit occurs when the liquid sensor is in its active/oscillating condition. (Gap sensor wet, Hi-Sens sensor dry). Model MEP3X1 reverse acting amplifier (in the adjacent amplifier type housing) reverses this head amplifier logic, pulses are signalled on the line and "normal" readout is indicated in the

MEP3L or MEP3R when the sensor is not oscillating (Gap sensor dry, Hi-Sens sensor wet).

Common specifications

Function

The head amplifier provides the RF drive circuitry for the liquid level sensors (gap type or Hi-Sens) or for interface detection sensors. These sensors are physically attached to the head amplifier, or mounted very close to the adjacent amplifier. Signals are transmitted along the two wire plant cabling to Electropulse control room units to provide readout.

Design concept - fail safety

The head amplifier electronic design features fail to safety (no pulse output) for any anticipated electronic, mechanical or wiring failure.

Hazardous area approval

Units are available approved intrinsically safe to ATEX, EN50014, EN50020. Certified IIC EExia IIC T4. (-40°C ≤ +85°C).

Specification

Power input: 12 volt dc from associated Electropulse control room unit (type L or R).
 Output signal: current pulses 2mA at 240Hz approximately square wave signalling to Electropulse control room unit.
 Operating frequency: 1 MHz or 3.7 MHz as required for the associated liquid or interface sensor.
 Ambient temperature: - 25°C to + 85°C. With potted electronics lower temperature limit is - 40°C.
Earthing
 Amplifier and sensor circuits are floating with respect to sensor housing. With metal bodied sensor, normal practice is that the sensor body is earthed.



Electropulse MEP3L Stand alone readout unit

Wall or DIN rail mounted polycarbonate single readout unit. Front panel LED indicators for liquid level sensor, normal, alarm and fault condition. Single relay outputs de-energised for alarm and fault.

1. Electropulse MEP3L Stand alone readout unit

Relay output

Energised for "Normal" condition. De-energised for "Alarm" condition after preset delay. De-energised for "Fault" condition. Double pole changeover contacts.

Rating:

500VA PF 0.4 on MEP3L at 250V rms

Ambient temperature: -10°C to +65°C

Power Consumption: 7VA

Cable Entry: Via cutouts in the base through rubber grommets to terminal strip

Protection: IP20

Common specification

Function

Provides power supply to sensor head amplifier and detects sensor state. Operates output relays and front panel LED indicators, providing delay adjustments and control test system. Design concept - fail safety. The readout unit electronic design feature fail to safety (alarm condition) for any anticipated electronic, mechanical or wiring failure.

Hazardous area approval

Units are available approved to ATEX II (1) G [EExia] IIC. This allows suitably specified plant cabling to be led directly in the hazardous area and connected to the Electropulse head amplifiers.

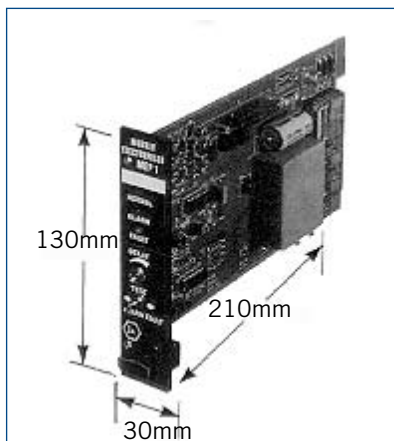

Electropulse MEP3R Rack mounted readout card

Single point readout card for use in a 19" rack system type MEP3B. Front panel LED indicators for liquid level sensor alarm and fault conditions. Independent alarm relay and fault relay.

2. Electropulse MEP3R Rack mounted readout card

Alarm relay output

Energised for "Normal" condition after preset delay. De-energised for "Fault" condition. (i) DPCO option, relay contact rating for MEP3R is 45VA at 250V rms. (ii) SPCO option, relay contact rating for MEP3R is 500Va at 0.4PF

Fault relay output

De-energised for "Normal" condition. Energised for "Fault" condition. SPCO relay, contact rating for MEP3R is 500VA at 0.4PF. Ambient temperature: -10°C to +55°C. Power consumption: 6VA

Installation consideration:

Allow at least a 50mm gap between each rack on multiple rack installations to allow air circulation. On installation of 4 or more racks, the fitting of a cabinet air circulating fan is recommended.

Specification

Input:

220/240V AC ± 10% 50/60 Hz
110/120V AC ± 10% 50/60 Hz

Front panel LED indicators

Green - Normal condition
Red - Alarm condition
Amber - Fault condition

NOTE:

Fault condition always triggers alarm. Normal condition is gap sensor wet, or Hi-Sens dry.

Delay:

Alarm to normal: less than 100msec
Normal to alarm: screwdriver adjustable from 1 to 10s.
Normal to fault: less than 100 msec.

Test:

Front panel push to test switch simulates alarm or fault conditions and triggers alarm relay (also fault relay on MEP3R).

Output:

Supply to Electropulse head amplifier (12V dc) is fully floating (galvanically isolated). The output is short circuit proof for short periods only.

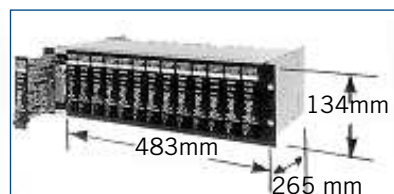

Electropulse MEP3B Rack for Electropulse cards

Rack system housing up to 14 MEP3R cards

Ordering information on page 17

Ultrasonic Liquid Level Sensor Selection

| | Fitting | Wetside Material | Design or Duty | Liquid Type | Temperature | Pressure | Sensor active | Approvals* |
|--------------|-------------------------------------|----------------------|--------------------|----------------------------------|-----------------|----------|---------------|------------|
| 332SD | 1" BSPT dual | 316 st. steel (cast) | Standard | Clean | -70°C to +150°C | 56b | Wet | H |
| 302SD | ¾" BSPT dual | 316 st. steel (cast) | Standard | Clean | -70°C to +150°C | 105b | Wet | H,P |
| 352SD | ¾" BSPT dual | 316 st. steel (cast) | Dual point | Clean | -70°C to +150°C | 105b | Wet | H,P |
| HL3SD | ¾" BSPT inside | 316 st. steel (cast) | Hi-Sens high alarm | Aerated, some solids | -70°C to +130°C | 100b | Dry | H |
| HD3SD | ¾" BSPT inside | 316 st. steel (cast) | Hi-Sens dual point | Aerated, some solids | -70°C to +130°C | 100b | Dry | H |
| 312SY | 1" BSPT dual | Epoxy & 316 st. st | Aerated liquids | Clean, aerated | -70°C to +130°C | 21b | Wet | |
| 312SU | 1" BSPT dual | P.P.S. | Corrosive liquids | Clean, aerated | -70°C to +130°C | 3.5b | Wet | H |
| 312SR | 1" BSPT dual | Polypropylene | Corrosive liquids | Clean, aerated | -70°C to +65°C | 3.5b | Wet | H |
| 323SY | ¾" BSPT inside | Epoxy & 316 st. st | Dirty liquids | Aerated, viscous, scale & solids | -70°C to +130°C | 21b | Wet | |
| 393SD | ¾" BSPT inside | 316 st. steel (cast) | Dirty liquids | Aerated, viscous, scale & solids | -70°C to +150°C | 56b | Wet | H,P |
| 373SD | ¾" BSPT inside | 316 st. steel (cast) | Multi-point (2-6) | Aerated, viscous, scale & solids | -70°C to +150°C | 56b | Wet | H,P |
| 30HSD | 1.1/2" outside | 316 st. steel (cast) | High temperature | Aerated, some solids | +1°C to +250°C | 50b | Wet | |
| 39HSD | ¾" BSPT inside | 316 st. steel (cast) | High temperature | Aerated, viscous, scale & solids | +1°C to +250°C | 50b | Wet | |
| 362SJ | ¾" BSPT dual | Epoxy & 316 st. st | Cryogenic | Aerated, some solids | -210°C to +65°C | 70b | Wet | |
| 366SJ | M6 inside | Epoxy | Miniature | Clean | -210°C to +65°C | 3.5b | Wet | |
| 389ST | 1.1/2" Flange | P.T.F.E. | Corrosive liquids | Aerated | -20°C to +130°C | 10b* | Wet | H |
| 402SD | ¾" BSPT dual | 316 st. steel (cast) | Interface duty | Clean | -70°C to +150°C | 105b | Wet or clear | H,P |
| 422SD | ¾" BSPT dual | 316 st. steel (cast) | High pressure | Clean | -70°C to +150°C | 280b | Wet | H,P |
| 433SD | ¾" BSPT inside | 316 st. steel (cast) | Interface duty | Clean | -70°C to +50°C | 105b | Wet or clear | H,P |
| 442SD | ¾" BSPT dual | 316 st. steel (cast) | Across pipeline | Clean | -70°C to +150°C | 105b | Wet or clear | H,P |
| 621SY | Clamp on 18-70mm dia. sight glasses | | Non-penetration | Clean | -20°C to +130°C | n/a | Pipe full | H |
| 601SY | Clamp on to flat sight glasses | | Non-penetration | Clean | -20°C to +130°C | n/a | Glass full | |

Most sensors are available with flange mounting. Consult factory for details.

Sensor operation may be upset by highly aerated or heavily contaminated liquids. Consult factory if in doubt.

For pressure above 50 bar, always consult factory before specifying.

*See note below.

| CODE | Sensor compatibility with Mobrey Measurement Systems | Not permissible with: |
|------------|--|--|
| | Compatible control system | |
| 80 | Control boxes MCU | Standard with 3m Cable, non approved. |
| U8H | Electrosensor MES or electropulse MEP | ATEX approved. For use with adjacent head amplifier* |
| SSH | Electrosensor MES | ATEX approved. Fitted with integral head amplifier. |
| PIH | Electropulse MEP | ATEX approved. Fitted with integral industrial head amplifier. |
| PMH | Electropulse MEP | ATEX approved. Fitted with integral marine head amplifier. |
| | *Note: Sensors for adjacent head use have 3m cable supplied. | Not 362, 366, 442, 621, 312SY Not 362, 366, 442, 621, 312SY |

| CODE | Standard Options | Permissible with: | Not permissible with: |
|--------------|---|---|--|
| E | Sensors available in extended length versions Specify dimension 'A' (See pages 4&5) when ordering For horizontal sensor mounting, Max 'A' = 915mm For vertical sensor mounting, Max 'A' = 3000mm | 302, 352, 312SY, 393, 373 HL3, HD3, 362, 389 373 only | 312SU, 312SR, 323SY 332, 39H, 30H, 366 402, 422, 442, 621, 601 |
| 1-6 | Specifies number of points on multi-point 373 Type | | |
| 1-5 | Specifies sensor gap size on 433 Type: 1 = 100mm: 2 = 200mm 3 = 300mm: 4 = 450mm 5 = 150mm | 433 only | |
| 32-80 | Specifies size of 621 Type: Contact factory for details | 621 only | |

| CODE | Special Options |
|--------------------------|--|
| X123 or M1 | A suffix in the form X*** may be used where a special option is supplied When ultrasonic crystals with a non-standard operating frequency are supplied, the suffix used will be in the form M*. |
| CODE | Special Options |
| T | Test switch on Electropulse integral head amplifiers. |

302SD 80 (These characters only used if required)

*Approvals:

H= ATEX II 1 G

P = PTB & Others – Consult factory.

Full details of Mobrey Measurement ultrasonic sensors for use in sludge blanket level or sludge density measurements are given in leaflet No IP250

Notes: Carbon dioxide (CO2): ultrasonic gap sensors will not operate in liquid CO2, which is highly attenuative.

Liquified petroleum gas (LPG): Hi-Sens sensors will not operate in LPG's such as propane & butane, which are low SG/low density.

Ordering information

Adjacent amplifier electronics

| | | |
|------------|----------------------------|---|
| MEP | Mobrey electropulse | |
| | Code | Approvals |
| | 3 | ATEX approved |
| | Code | Amplifier type |
| | AI | Adjacent mounted sensor head amplifier IP65 |
| | XI | Reverse acting amplifier (IP65) |
| | Code | Frequencies |
| | 3 | 1 MHz frequency |
| | 4 | 3.7 MHz frequency |
| | Code | Circuitry |
| | C | Single unit |
| | Code | Materials |
| | S | Stainless steel } to special order only |
| | P | Polycarbonate |
| | Code | Test facility |
| | N | Standard |
| | T | Test switch |
| | Code | Environment |
| | O | Standard |
| | P | Potted |

| | | | | | | | |
|------------|----------|---------------|----------|----------|----------|----------|--------------------------|
| MEP | 3 | AI / 3 | C | P | N | O | Typical model no. |
|------------|----------|---------------|----------|----------|----------|----------|--------------------------|

Control room electronics

| | | |
|------------|----------------------------|---------------------------|
| MEP | Mobrey electropulse | |
| | Code | Unit Option |
| | 3 | Intrinsically safe (ATEX) |
| | Code | Unit Type |
| | R | Rack card |
| | L | stand alone unit |
| | Code | Voltage input |
| | 1 | 230 volts |
| | 2 | 115 volts |
| | Code | Relay Output |
| | D | DPCO Relay |
| | S | SPCO Option on rack card |

| | | | | |
|------------|----------|--------------|----------|--------------------------|
| MEP | 3 | R / 1 | D | Typical model no. |
|------------|----------|--------------|----------|--------------------------|

Rack Unit

| | | |
|------------|----------------------------|-----------------------------------|
| MEP | Mobrey Electropulse | |
| | Code | Unit Option |
| | 3 | Intrinsically safe (ATEX) |
| | Code | Number of connections |
| | B | Rack (for cards of one type only) |
| | 01-14 | Connectors fitted for rack cards |

| | | | |
|------------|----------|---------------|--------------------------|
| MEP | 3 | B / ** | Typical model no. |
|------------|----------|---------------|--------------------------|

The Emerson logo is a trade mark and service mark of Emerson Electric Co.
Rosemount is a registered trademark of Rosemount Inc.
Mobrey is a registered trademark of Mobrey Ltd.
All other marks are the property of their respective owners
We reserve the right to modify or improve the designs or specifications of product and services at any time without notice.

International:

**Emerson Process Management
Mobrey Measurement**
158 Edinburgh Avenue, Slough,
Berks UK SL1 4UE
T +44 (0)1753 756600
F +44 (0)1753 823589
www.mobrey.com

Americas:

**Emerson Process Management
Rosemount Inc.**
8200 Market Boulevard
Chanhassen, MN USA 55317
T (US) (800) 999-9307
T (International) 952) 906-8888
F (952) 949-7001

Literature reference number : IP201 November 2005

