

Damcos™ Solenoid Operated Directional Control Valves



General Description and Application Advantages

Basically, these solenoid operated directional control valves are for directing and stopping flow at any point in a hydraulic system.

- Efficient control of greater hydraulic powers without increasing solenoid power consumption.
- Installed cost and space savings from higher power/ weight-and-size ratio.
- Reduced internal leakage reduces power losses, increases system efficiency: the result of improved manufacture of spools and bores.
- Installation flexibility resulting from choice of numerous combinations of solenoid connectors and locations.
- Multi-fluid capability without need to change seals.
- Higher sustained machine productivity and higher up-time because of proven fatigue life and endurance, tested over 20 million cycles.

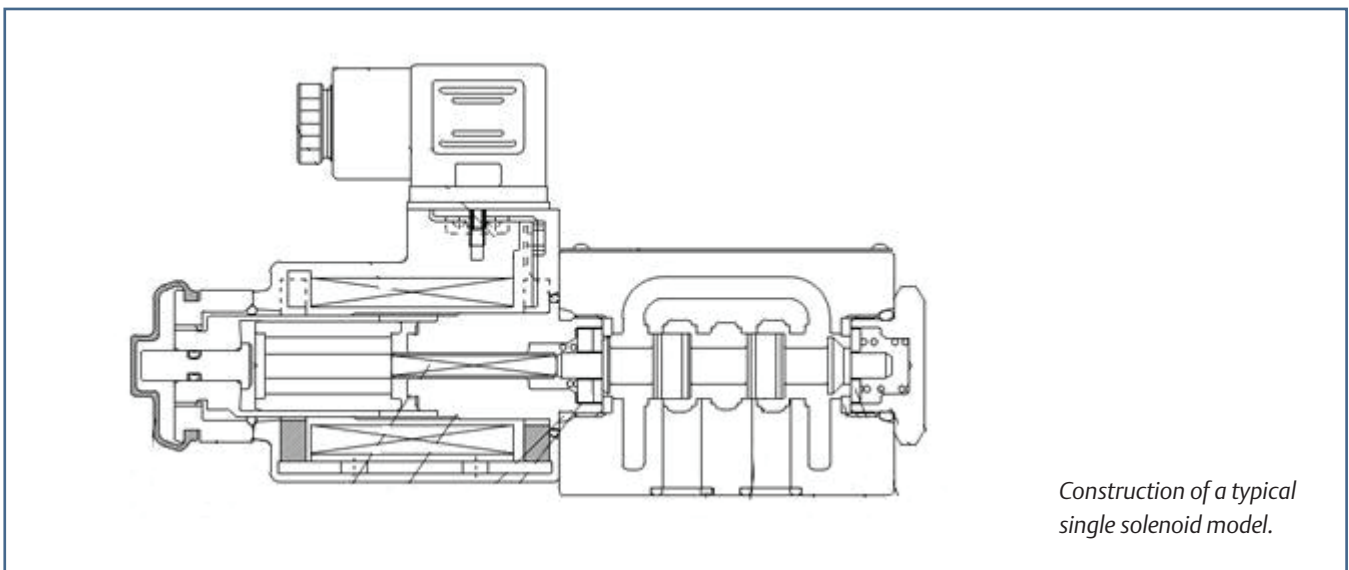

Construction of a typical single solenoid model.

All valves are delivered with manual push-button for local override.

Versions

Type C6S:

4-way, 3-position directional valve, with two solenoids; positioning of spool at rest is obtained with centring springs.

Type A3X/H3X

4-way, 2-position directional valve, with one solenoid; spool position at rest is obtained with a return spring.

Type E3X:

4-way, 2-position directional valve, with two solenoids; with mechanical detent of the extreme spool positions when solenoids are de-energized.

Performance ratings

(Working with mineral oil of viscosity of 36 cSt at 50°C)

Performance ratings		
Maximum working pressure		
	Ports P A B	350 bar
	Port T	140 bar
Maximum flow rate		
	From port P to A or B	80 l/min
	From port A or B to T	80 l/min
Ambient temperature range		-20°C to +60°C
Fluid temperature range		-20°C to +70°C
Fluid viscosity range		15-300 cSt
Recommended filtration		≤ 25 µm absolute
Burst pressure		680 bar
Mass		
	Double	2.0 kg 1.8 (AC) 2.0 (DC)
	Single	1.5 kg 1.4 (AC) 1.5 (DC)

Operating Limits

The curves define the flow rate operating fields according to the solenoid valve pressure with DC and AC solenoids. The values have been obtained with 36 cSt, temperature 50° C, filtration 25µm and with solenoids at rated temperature and supplied with voltage equal to 90% of the nominal voltage.

Performance Curve

Pressure Loss Characteristics					
Type	Spool type	Connections:			
		P→A	P→B	A→T	B→T
		Curves on the graph:			
SA-G01	A3X, H3X	E	E	E	E
	E3X	F	F	F	F
	C6S	F	F	F	F

Hydraulic Operating Fluid Viscosity 32cSt

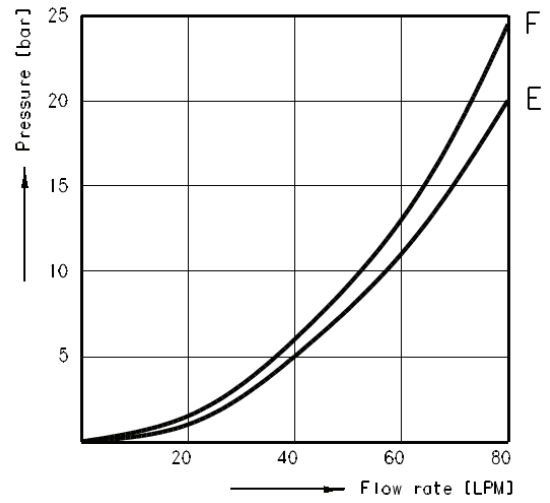

Pressure-Flow Volume Allowable value		
Type	Spool type	Curve
SA-G01	A3X, H3X	A
	E3X	B
	C6S	C

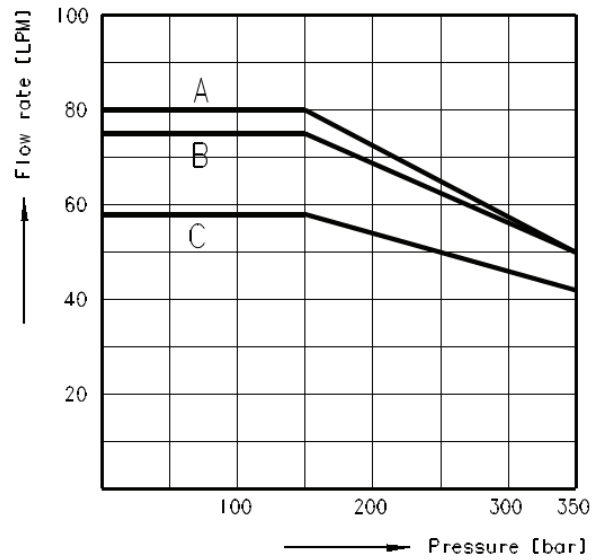

Dimensions

AC Solenoid

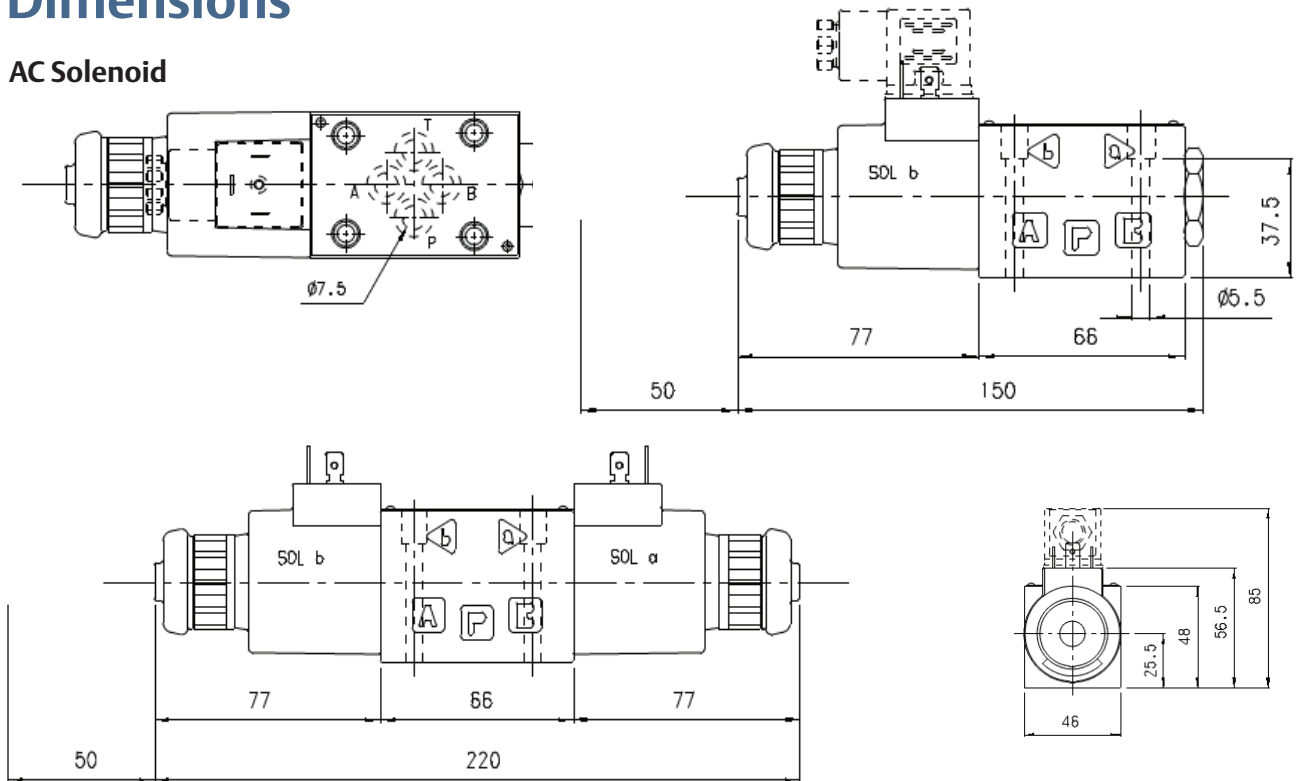

Space required for coil removal

DC Solenoid

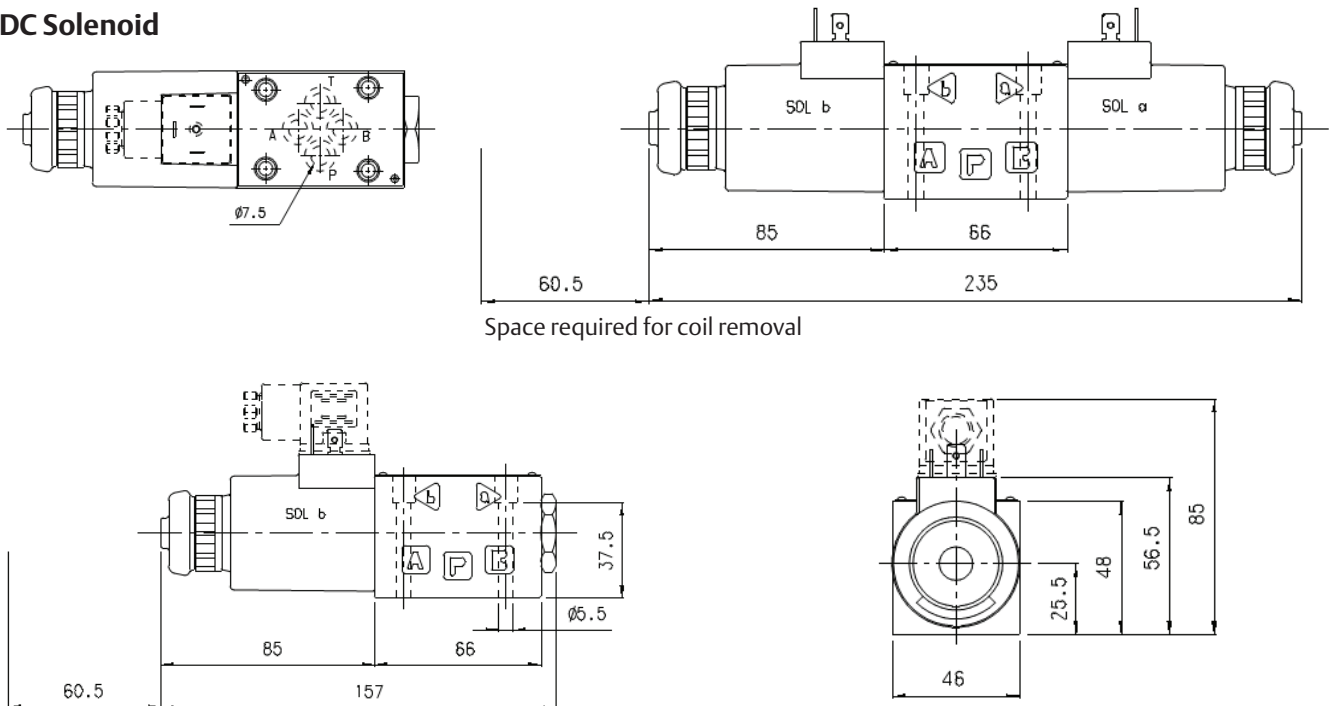

Space required for coil removal

Optional

Lock for manual override. It is used when mechanical blocking is required in case of service or electrical failure.

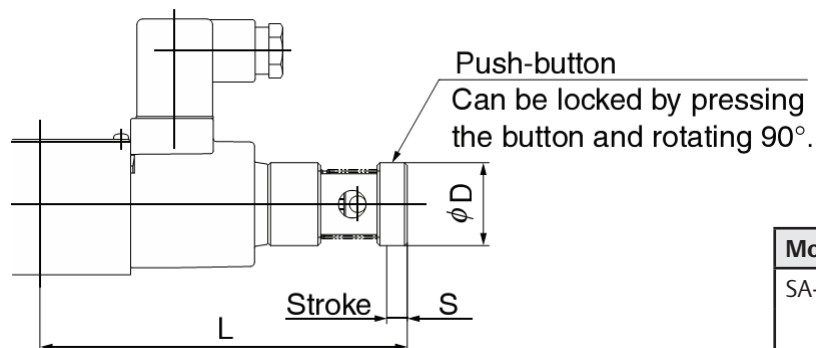

Model no.		L	S	D
SA-G01	AC solenoid	133,5	7,5	30
	DC solenoid	140,5	9,5	35

Mounting Interface

ISO 4401 size 03
 ANSI/B93.7M size D03
 CETOP RP65H size 3
 DIN 24340 NG6
 IEC 144 - IP65

Electrical Specifications

Supply voltage fluctuation: +5% - 10% Vnom
 Max. switch on frequency: 10.000 ins/hr
 Duty cycle: 100%
 Electromagnetic compatibility (EMC):
 - Emissions: EN 50081-1
 - Immunities: EN 50082-2

Low voltage (in compliance with): 73/23/CEE 96/68/CEE
 Class of protection acc. to IEC 144:
 - Atmospheric agents: IP 65
 - Coil insulation: Class H
 - Impregnation: Class F

Nominal voltage and frequency		Power consumption at inrush	Power consumption at holding	Consumed current	Power
V	HZ	VA (± 5%)		A (± 5%)	W (± 5%)
110	50	220	63	-	-
220	50	220	63	-	-
110	60	200	-	-	-
220	60	200	-	-	-
24	DC	-	-	1.1	26

Ordering

Coil rating:	ID-No	Type:	Symbol:
24 V DC	160L8050	SA-G01-E3X-G-D2-31ES	
110 V 50 Hz - 120 V 60 Hz	160L8051	SA-G01-E3X-C115-31ES	
220 V 50 Hz - 230 V 50 Hz - 240 V 60 Hz	160L8052	SA-G01-E3X-C230-31ES	
24 V DC	160L8054	SA-G01-A3X-G-D2-31ES	
110V 50 Hz - 120 V 60 Hz	160L8055	SA-G01-A3X-C115-31ES	
220 V 50 Hz - 230 V 50 Hz - 240 V 60 Hz	160L8056	SA-G01-A3X-C230-31ES	
24 V DC	160L8058	SA-G01-H3X-G-D2-31ES	
110 V 50 Hz - 120 V 60 Hz	160L8059	SA-G01-H3X-C115-31ES	
220 V 50 Hz - 230 V 50 Hz - 240 V 60 Hz	160L8060	SA-G01-H3X-C230-31ES	
24 V DC	160L8062	SA-G01-C6S-G-D2-31ES	
110 V 50 Hz - 120 V 60 Hz	160L8063	SA-G01-C6S-C115-31ES	
220 V 50 Hz - 230 V 50 Hz - 240 V 60 Hz	160L8064	SA-G01-C6S-C230-31ES	

Accessories

ID-No:	Type:	Description:
160L8070	EDB14-A (for AC solenoid)	Lock for manual override
160L8071	EDB14-D (for DC solenoid)	Lock for manual override

©2012 Emerson Process Management. All rights reserved.

The Emerson logo is a trademark and service mark of Emerson Electric Co. Damcos and the Damcos logotype are registered trademarks of Damcos A/S. Rosemount and the Rosemount logotype are registered trademarks of Rosemount Inc. TankRadar, LevelDatic and MAS 2600 are trademarks of Rosemount Tank Radar AB. Damcos A/S and Rosemount Tank Radar AB are members of the Emerson Process Management family of companies. All other marks are the property of their respective owners.

Emerson Process Management

Damcos A/S
Aaderupvej 41
DK-4700 Naestved
T +45 5578 7200
F +45 5578 7272

www.EmersonProcess.com/mtm

The contents of this publication are presented for information purposes only, and while effort has been made to ensure their accuracy, they are not to be construed as warranties or guarantees, express or implied, regarding the products or services described herein or their use or applicability. All sales are governed by our terms and conditions, which are available on request. We reserve the right to modify or improve the designs or specifications of our products at any time without notice.