

The Firetex Cable Tray Protection System is based upon the encapsulation of Thermal Ceramics Firemaster Blanket, tested at Mobil's Paulsboro Research Laboratory in New Jersey and earlier by Amoco Research. The Firetex system, constructed of two 25mm thick foil-faced blankets, enclosed within a silicone coated glass cloth, has been independently tested at Warrington Fire Research Station and has been proven to provide 30 minutes cable integrity protection when exposed to a hydrocarbon fire hazard.

The system comprises two halves, the lower of which is banded to the cable rack or tray thus allowing open access to the cables therein when the top section is removed. On larger trays an open stainless steel mesh cover is supplied to carry the weight of the top cover and prevent it from laying onto the cables. The top cover is fitted by means of fire grade velcro overlaps which fold to the underside and allow the system to shed rain water, etc. Top and bottom sections are staggered by half when installed.

Top Cover

2 x 25mm Thk 128 kg/m² Density Foil Faced Ceramic Blanket
1 x 25mm Thk Side Panels

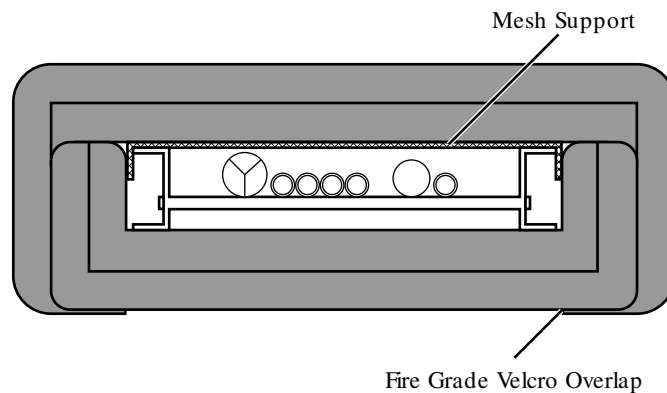

Bottom Cover

2 x 25mm Thk 128 kg/m² Density Foil Faced Ceramic Blanket

The body of the system is two layers of 25mm thick, foil faced, 128 kg/m³ density, Firemaster blanket. In accordance with the overlap arrangement employed in the product testing, the sides of the top section are one layer in thickness which, when installed onto the bottom section, create a thickness of 75mm at the sides.

The two components of the system are encapsulated within silicone coated glass cloth which provides protection from adverse environmental conditions. Mesh supports and bottom cover banding are stainless steel.

The very nature of typical cable rack/tray installations dictates that a site survey will normally be required prior to design and manufacture. Such visits will enable our engineers to design covers for transition sections, tees, bends, etc.

HEAD OFFICE

MCL House, Adams Close, Heanor Gate Industrial Estate,
Heanor, Derbyshire DE75 7SW. England.
Telephone: + 44 (0)1773 535365
Facsimile: + 44 (0)1773 533478

URL: <http://www.mclunitex.co.uk>
e-mail: mcl@isolatedsystems.com

Firetex Cable Tray Protection System Material Specification

TOP COVER

Firemaster foiled ceramic blanket 25mm thick 128 kg/m³ density in two layers with a single layer to sides.
Encapsulated in silicone coated glass cloth. 100mm wide velcro overlap to undersides and adjoining sections.

BOTTOM COVER

Firemaster foiled ceramic blanket 25mm thick 128 kg/m³ in two layers. Encapsulated in silicone coated glass cloth.

SECURING

Stainless steel banding to retain bottom cover.

SUPPORT

Stainless steel wire mesh to support span of top cover on larger trays.

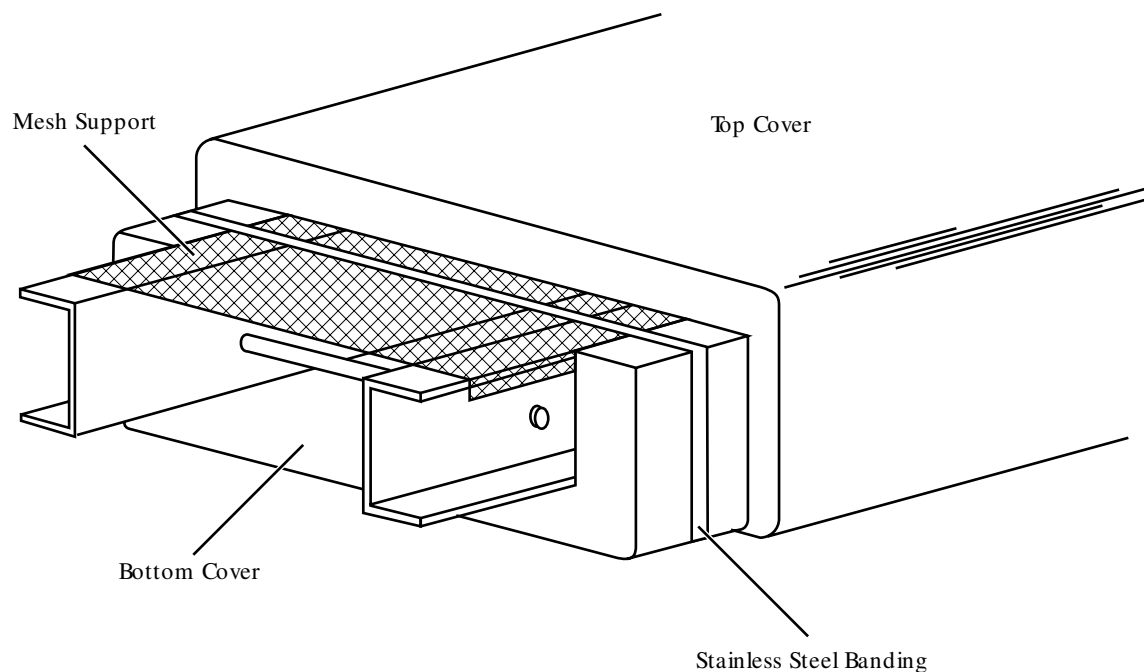

HEAD OFFICE

MCL House, Adams Close, Heanor Gate Industrial Estate,
Heanor, Derbyshire DE75 7SW. England.
Telephone: + 44 (0)1773 535365
Facsimile: + 44 (0)1773 533478

URL: <http://www.mclunitex.co.uk>
e-mail: mcl@isolatedsystems.com