

Damcos™ LPU-D-Ex-d-IIC for double-acting actuator



LPU-D-Ex-d-IIC (and LPU-D-Ex-d-ia-IIC)

The LPU is designed for the control of double-acting actuators requiring hydraulic pressure for operation in open or closed position.

The LPU is approved according to the ATEX directive 94/9/EC and is built to meet the requirements for mounting in hazardous areas Group II, Zone 0 (only actuator), If ia-version LPU also in Zone 1. Zone 2, Gas class 2C and temperature class T5 or T6.

Shielded 230V supply cable must always be used.

For further technical information please see general data sheets for the standard LPU.

Control type: MTM-BUS / P-NET®

Zener-barrier

The LPU Ex-d-ia-IIC is equipped with an internal zener-barrier, built-in in the top cover, which then holds an Ex-d cable gland. This feature makes it possible to place the actuator and an external position indicator even in zone 0 (connected to the LPU through piping), and connect the position indicator directly to the LPU Zener barrier. The LPU may be located in zone 1.

NOTE!

When LPU is equipped with zener barrier, the 24VDC power supply to the LPU should be connected 0 to ground. Else even a brief connection of +24V to ground will destroy the zener barrier.

Temperature Watchdog

The LPU is equipped with a patented "temperature watchdog" which enables the LPU to operate in hot ambient temperatures and still be able to ensure that the LPU surface temperature never exceeds the allowed maximum, according the appropriate temperature class (T5 or T6).

Just before the amount of heat stored in LPU gets critical, the motor is switched off.

Control type: MTM-BUS / P-NET®, with the option of hardwire control. Please see LPU P-NET datasheet.

Operation LPU-D-Ex-d-IIC

When the motor and solenoid valve are activated the oil is sucked from tank through the suction filter to the pump and pumped through the solenoid valve and the pilot operated check valve (13) to the actuator port B. This causes the actuator to open the valve. The oil from actuator port A flows back through the pilot operated check valve (5) (which is opened by the pressure in the

B-line) and returns through the solenoid valve to the tank.

When the valve is fully open, the pressure rises to 150 bar, which causes the pump safety valve to open so that the oil flows back to tank. The motor and the solenoid valve are then de-energized.

The actuator is now hydraulically locked in position by the pilot operated check valves.

In case of a major rise in temperature, the pressure may rise. This will not cause any problems because of the actuator relief valve (6) and (11), which will open at approx. 225 bar.

Closing the valve follows exact the same procedure, except that the solenoid valve is not activated which causes the ports A and B to be reversed.

When the motor is running the direction of oil-flow is solely determined by the activation of the solenoid valve.

Hydraulic diagram for LPU-D-Ex-d-IIC

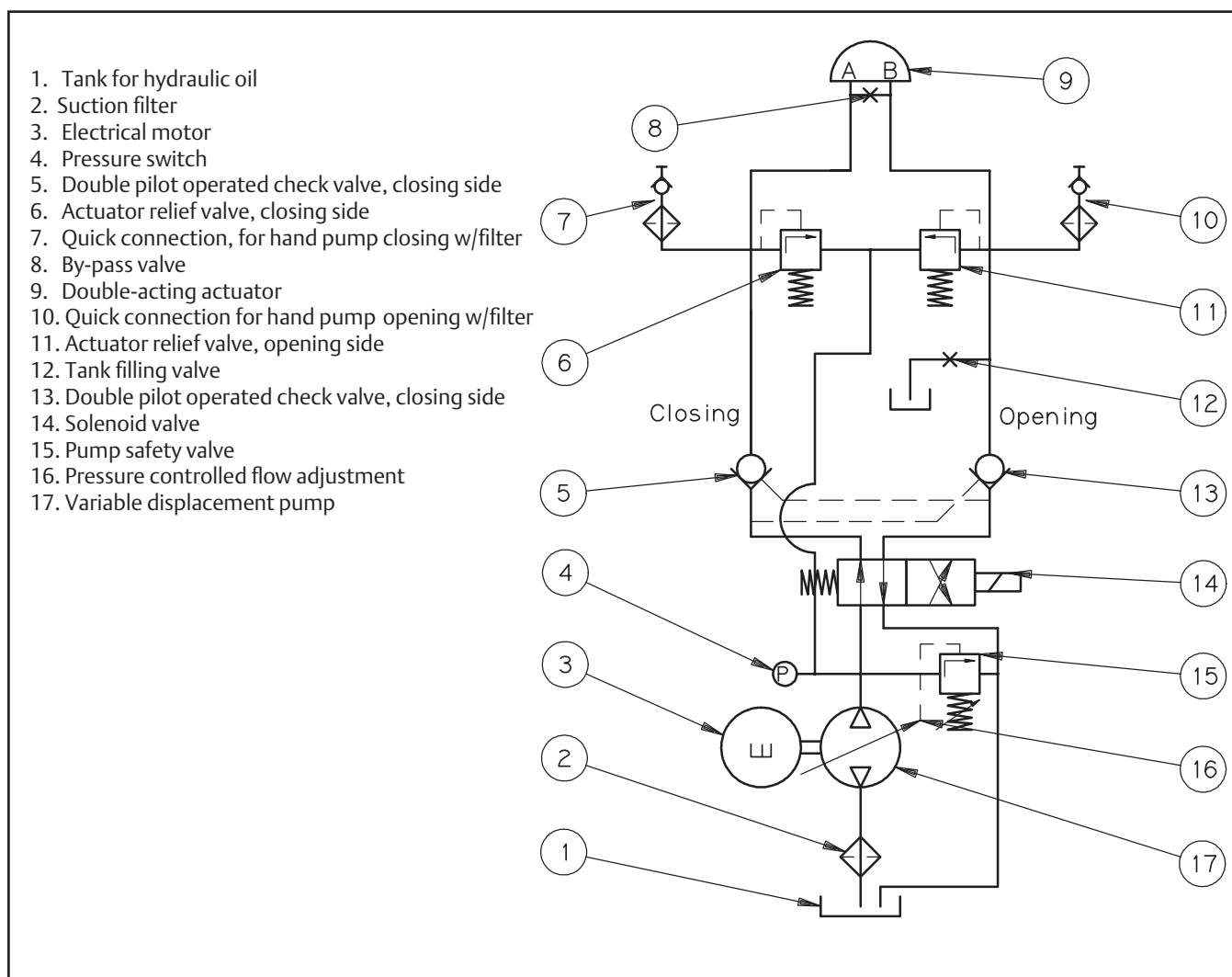

Emergency operation LPU-D-Ex-d-IIC

...with portable hand pump

A portable hand pump is connected to the two quick connections (7) and (10), which are directly connected to the actuators ports A and B. The actuator can be activated in any of the two directions, until the required position is reached. If too high pressure is applied to the LPU, the relief valve let the oil flow to the tank. The hand pump is dismantled. The actuator is hydraulically locked in any position.

...with key (only possible up to BRC 500)

The cross-over valve in the actuator is opened, the key is used to turn the actuator, the cross-over valve is closed. The actuator is hydraulically locked in any position.

...with permanently connected (bulkhead-mounted) hand pump

Open or close is selected on the hand pump block lever, the hand pump is activated until the required position is reached. The actuator is hydraulically locked in any position.

Note!

After emergency operation, remote control is automatically in charge.

Main dimensions BRC

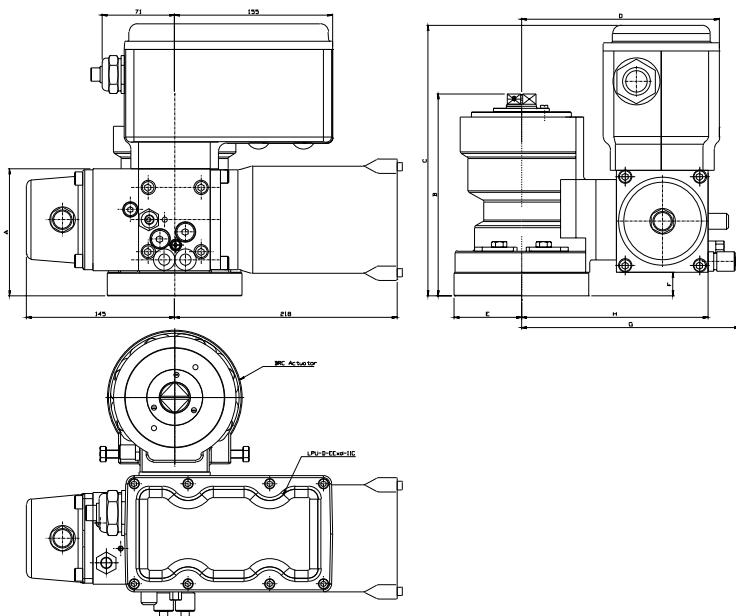

	A	B	C	D	E	F	G	H
*BRC 125	116.5	149.5	262.5	175	48	16.5	194.5	163
BRC 250	121	174.5	267	182	59	21	201.5	170
BRC 500	124.5	199	270.5	195	66	24.5	214.5	183
BRC 1000	133	229	279	207	80	33	226.5	195
BRC 2000	144	271	290	219	96	44	238.5	207
BRC 4000	153	319	299	247	150	53	266.5	235
BRC 8000	172.5	380	318.5	279	157	72.5	298.5	267
BRC 16000	203	470	349	302	175	103	321.5	290

All dimensions in mm. * BRC 125/LPU has to be bulkhead mounted.

Main dimensions KC

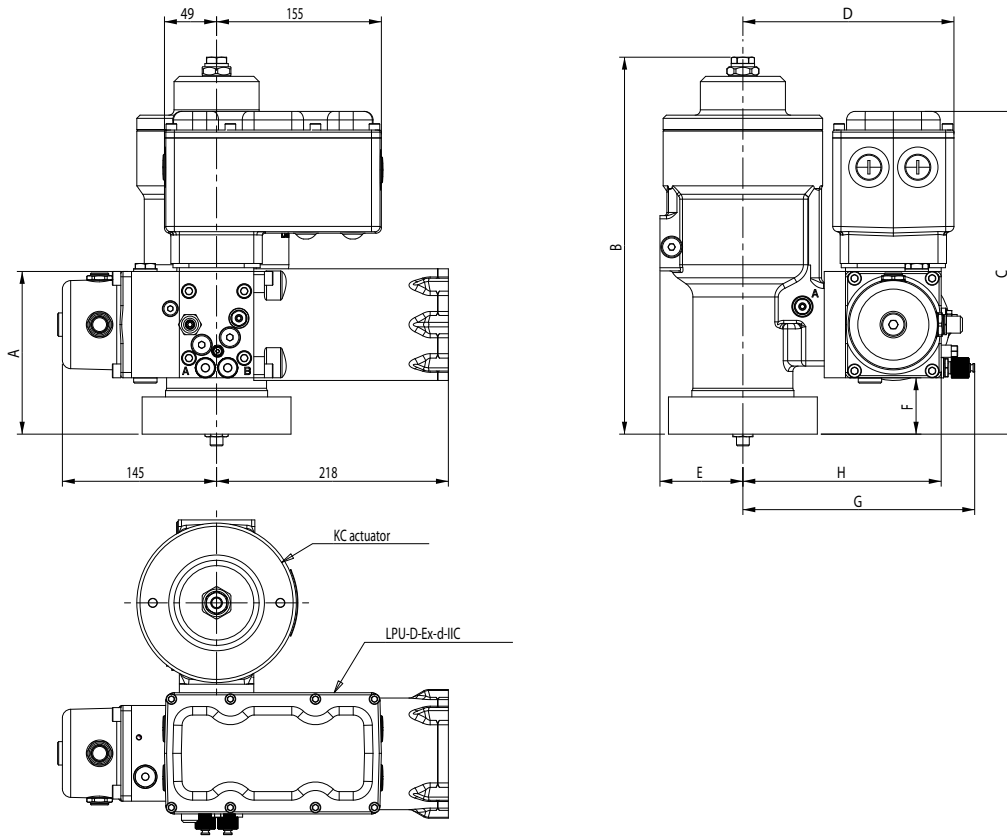

	A	B	C	D	E	F	G	H
KC 65	115.5	166	266	168.5	-	15.5	189.5	158
KC 125	123	211	273.5	170.5	52	23	191.5	160
KC 250	153	357	303.5	198.5	77	53	219.5	188
KC 325	176.5	477	327	224	-	76.5	245	213.5
KC 400	195.5	538.5	346	224	-	95.5	245	213.5

All dimensions in mm.

©2012 Emerson Process Management. All rights reserved.

The Emerson logo is a trademark and service mark of Emerson Electric Co. Damcos® and the Damcos logotype are registered trademarks of Damcos A/S. All rights reserved.

The contents of this publication are presented for information purposes only, and while effort has been made to ensure their accuracy, they are not to be construed as warranties or guarantees, expressed or implied, regarding the products or services described herein or their use or applicability. Standard Terms and Conditions of Sale can be issued by contacting Damcos A/S. We reserve the right to modify or improve the designs and specifications of our products at any time without notice.

Emerson Process Management

Damcos A/S
Aaderupvej 41
DK-4700 Naestved
T +45 5578 7200
F +45 5578 7272

www.EmersonProcess.com/mtm