

# Damcos™ Hand Pump - Electro-hydraulic

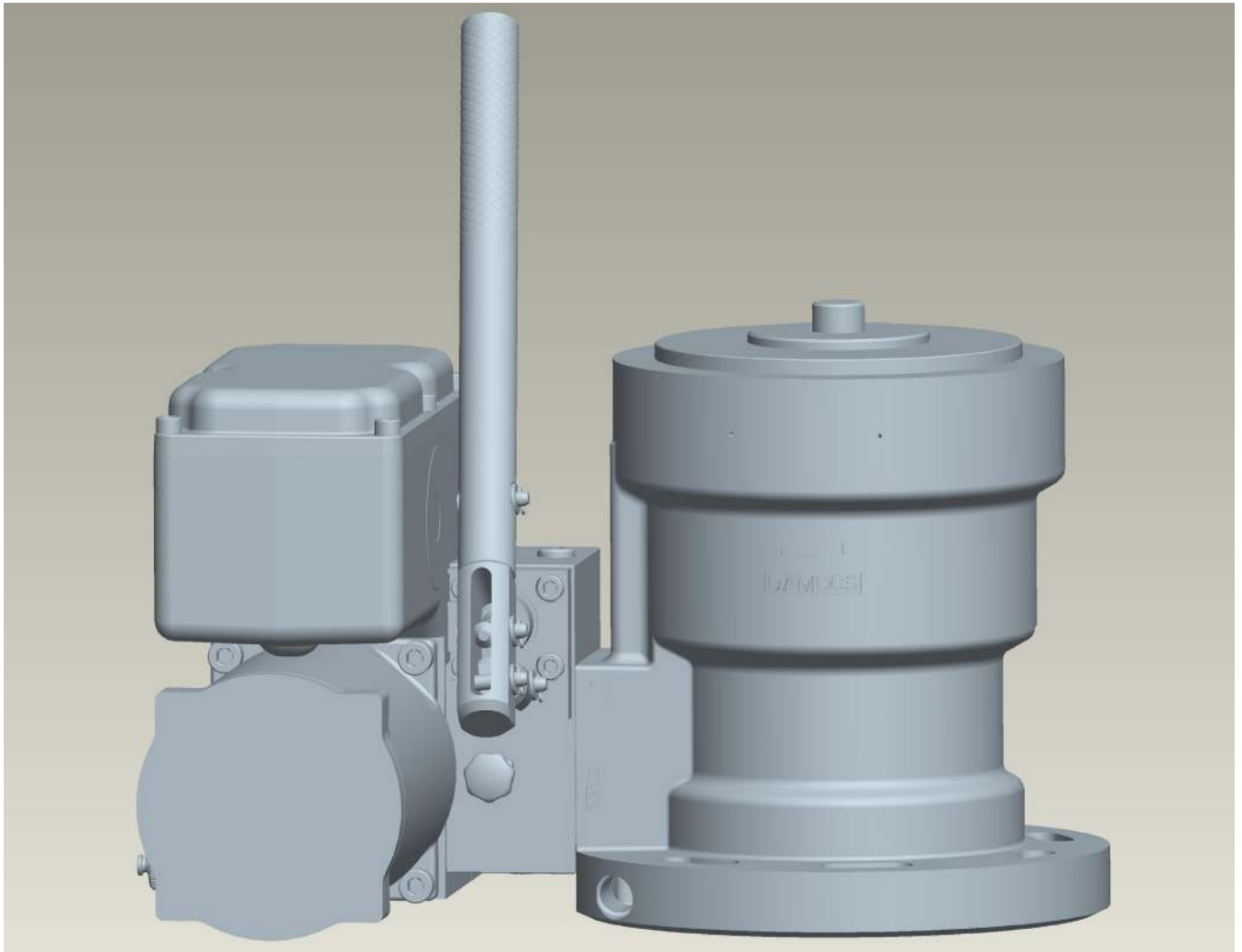

## General Description

The hand pump is always mounted with LPU or LPUM. HP-LPU can be mounted directly or as bulkhead mounted. HP-LPUM can be mounted directly on actuator only.

The handpump itself does not require any tank, but general tank requirements for LPU must be fulfilled.

### Note!

The very large actuators are not recommendable to be operated by standard handpump - ask for directions.

## Application

Hand pump type	Range
HP-LPU BRC/F/KF (Direct)	BRC /F 125 - 8000 & KF 65 - 250
HP-LPU KC (Direct)	KC 65 - 400
HP-LPUM BRC/F/KF (Direct)	BRC/F 125 - 500
HP-LPUM KC (Direct)	KC 65 - 125
HP-LPU BRC/F/KF (BB)	BRC/F 125 - 8000 & KF 65 - 250
HP-LPU KC (BB)	KC 65 - 400

Please note that oil volume must be taken into consideration to determine the correct VPI gear ratio.

## Direct and Bulkhead Mounted Handpump

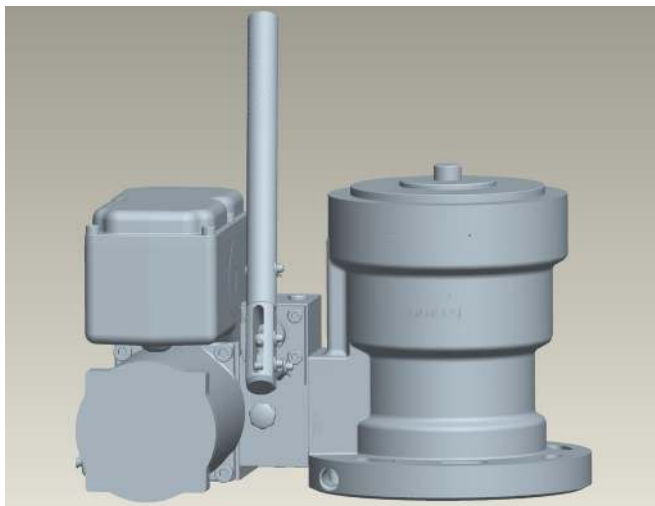

Direct mounted hand pump.

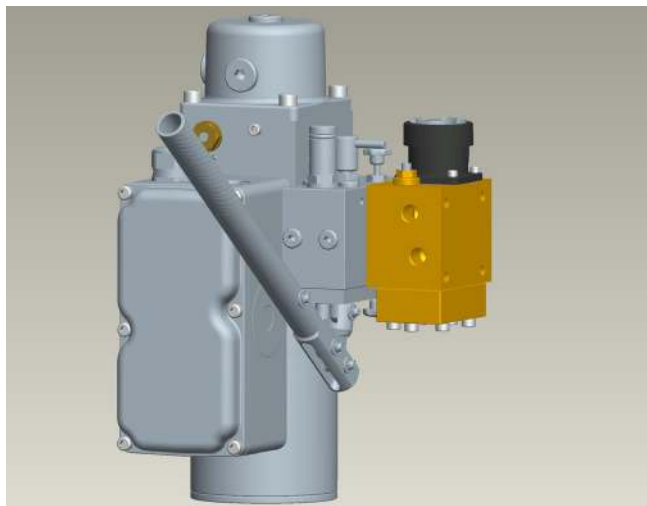

Bulkhead mounted hand pump.

## Main Data

Mounting	Prepared for actuator and bulkhead block interface
Maximum operation pressure	135 bar
Test pressure	225 bar
Maximum hand pump pressure	135 bar
Weight without oil	4.3 kg BRC/F KF version 5 kg KC version
Oil displacement per double stroke	8 cm <sup>3</sup>
Oil viscosity range	From 15 to 200 cSt
Temperature range	From -25° to 80° C
Recommended oil filtration	ISO Solid contaminant code 18/15 or NAS 160/10

## Material

Housing / Cover	Brass
Spindle / Piston	Brass
Valves	Brass
Screws / Sign plate / Rivet	Stainless steel
Sealings	NBR (Acrylonitrile butadiene)

## Bulkhead Installation Requirement

- To gain maximum hand pump performance it is of significant importance that the pipes between hand pump and actuator are well de-aired.
- Distance between hand pump and actuator must not exceed 80 m.
- Bulkhead mounted hand pump can be with or without VPI.
- Specific rules related to hand pump applications can be found in related instructions.

# Hydraulic Diagram for Direct Mounted LPU Handpump

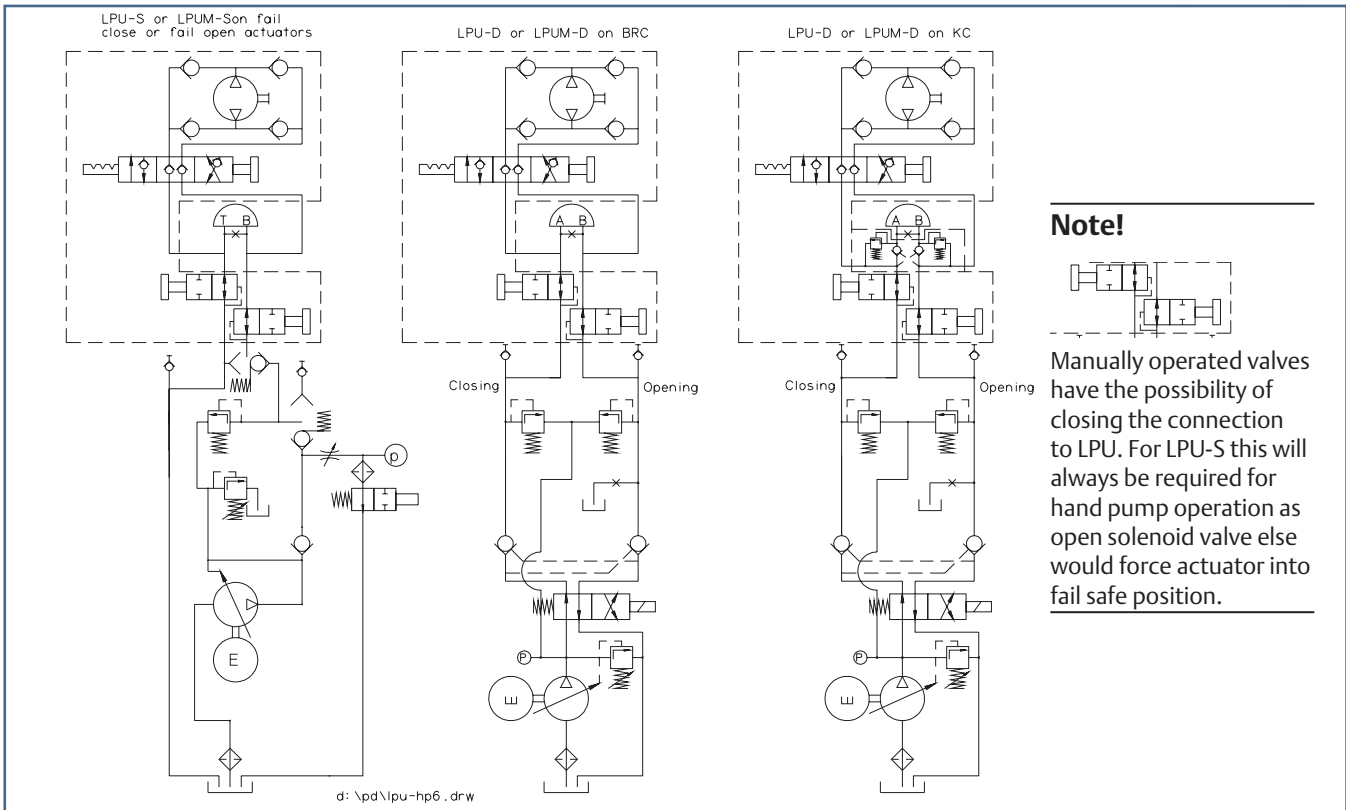

# Hydraulic Diagram for Bulkhead Mounted LPU Handpump

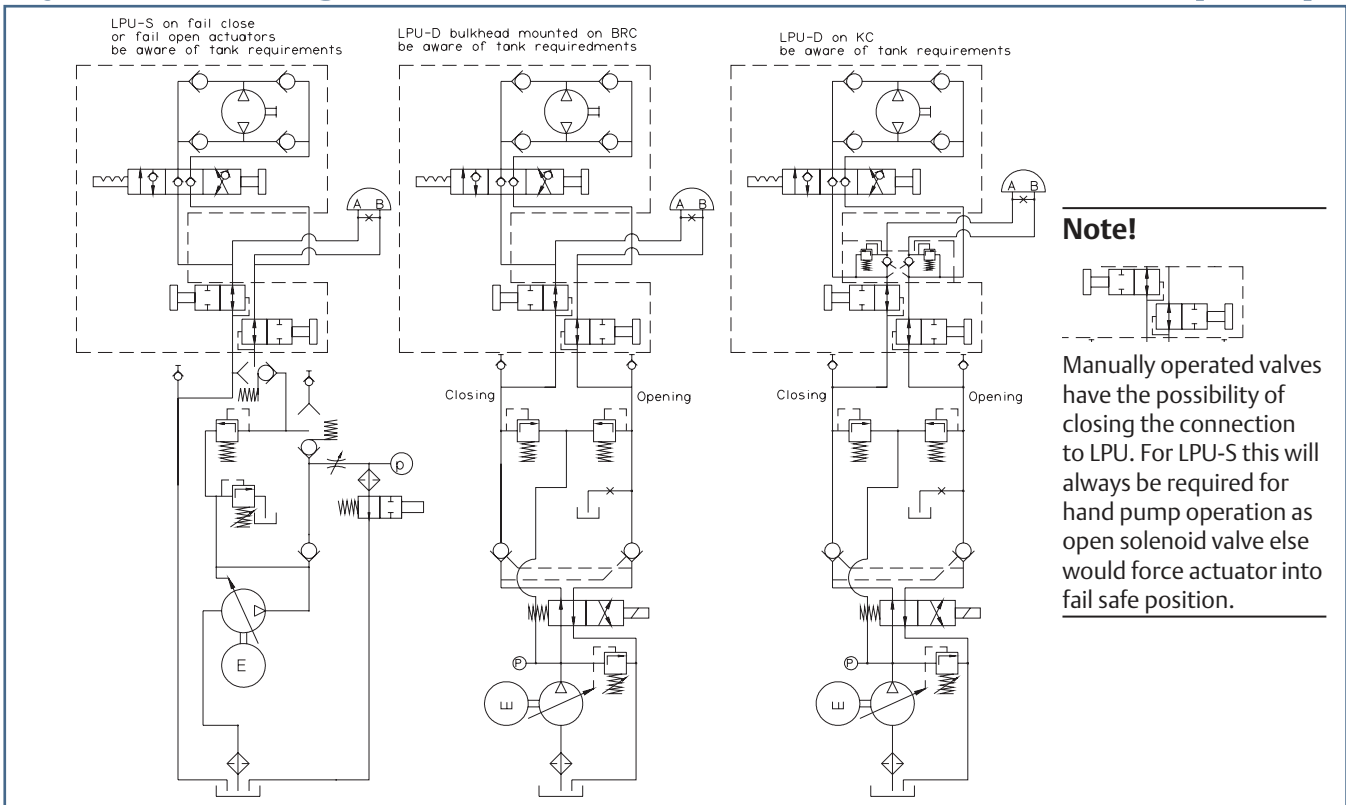

# Dimensions for Handpump

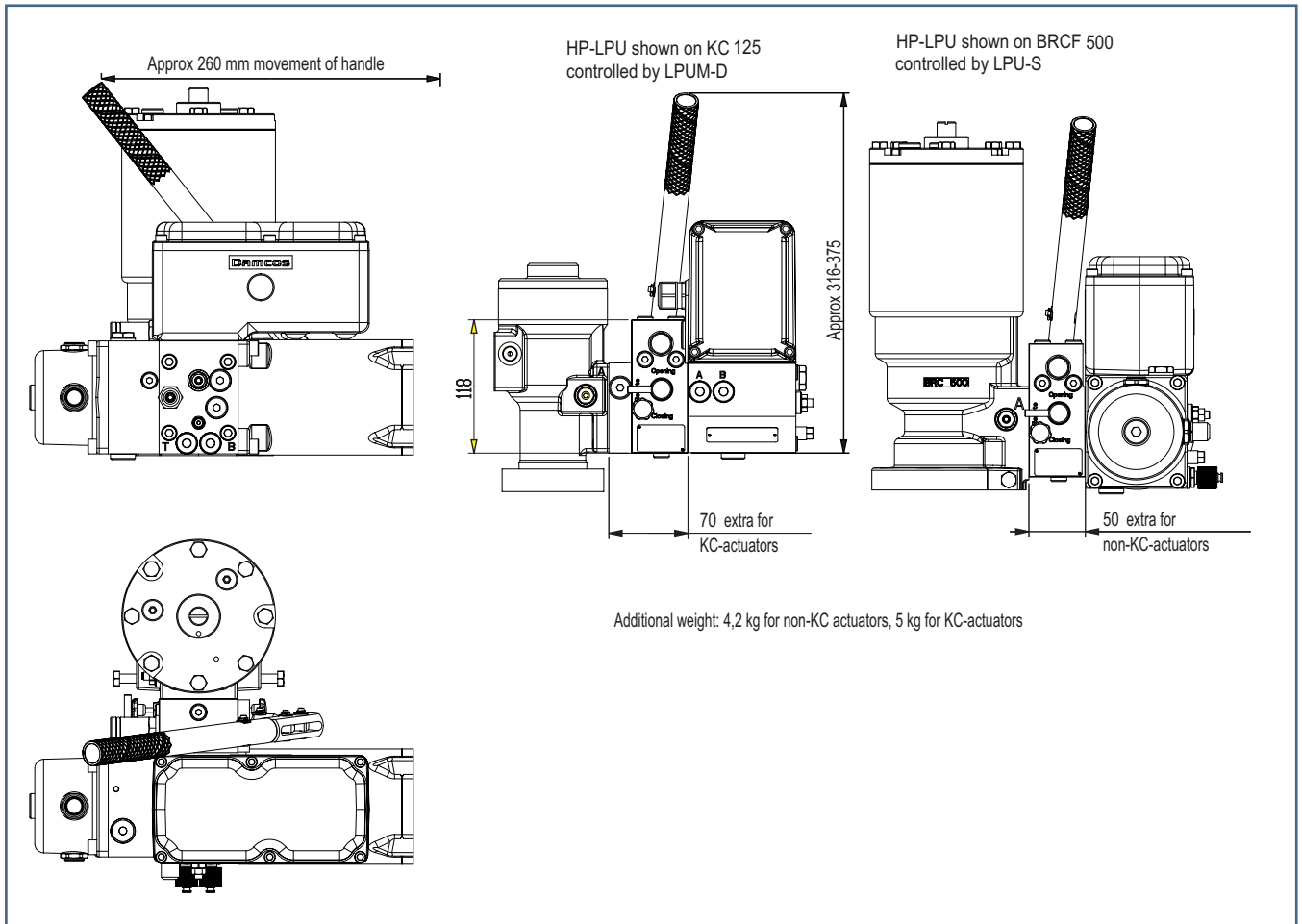

©2015 Emerson Process Management. All rights reserved.

The Emerson logo is a trademark and service mark of Emerson Electric Co. Damcos and the Damcos logotype are trademarks of Damcos A/S. All other marks are the property of their respective owners.

**Emerson Process Management**

Damcos A/S  
Aaderupvej 41  
DK-4700 Naestved  
T +45 5578 7200  
F +45 5578 7272

[www.EmersonProcess.com/mtm](http://www.EmersonProcess.com/mtm)

The contents of this publication are presented for information purposes only, and while effort has been made to ensure their accuracy, they are not to be construed as warranties or guarantees, expressed or implied, regarding the products or services described herein or their use or applicability. Standard Terms and Conditions of Sale can be issued by contacting Damcos A/S. We reserve the right to modify or improve the designs and specifications of our products at any time without notice. Damcos A/S accepts no responsibility for any errors that may appear in this publication.